

**OPERATOR'S AND UNIT  
MAINTENANCE MANUAL INCLUDING  
REPAIR PARTS AND SPECIAL TOOLS  
LIST**

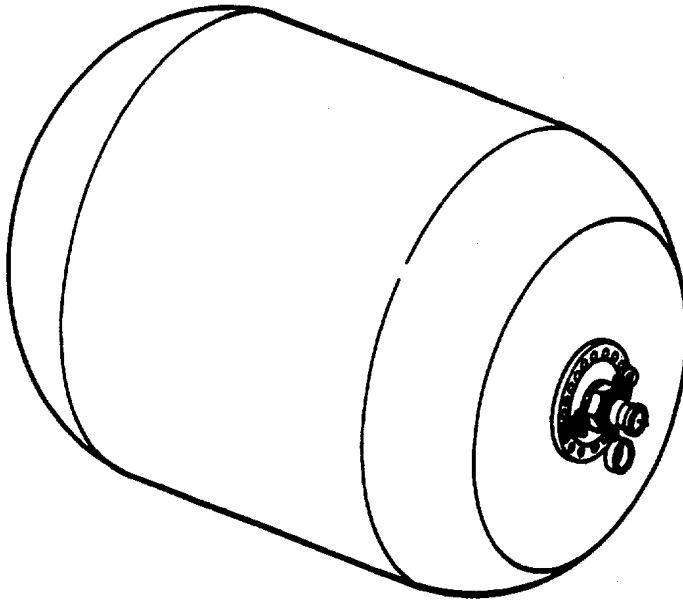

**500 GALLON COLLAPSIBLE  
LIQUID FUEL DRUM,  
LOW TEMPERATURE  
MODEL 91097  
NSN: 8110-01-327-1981**

<b>OPERATING INSTRUCTIONS</b>	<b>2-1</b>	■
-------------------------------	------------	---

<b>UNIT MAINTENANCE</b>	<b>4-1</b>	■
-----------------------------	------------	---

<b>UNIT TROUBLESHOOTING</b>	<b>4-3</b>	■
---------------------------------	------------	---

<b>REPAIR PARTS AND SPECIAL TOOLS LIST</b>	<b>C-1</b>	■
--	------------	---

**Distribution Statement A: Approved for public release, distribution is unlimited.**

## WARNINGS

Do not use near open flame or excessive heat. Death or personnel injury could occur due to exploding or burning fuel.

Do not allow smoking within 100 feet of fuel drum filling area. Death or personnel injury could occur due to exploding or burning fuel.

Fuels are hazardous flammable liquids. Avoid getting fuel on the body or clothing. Death or serious injury could occur if safety precautions are not strictly observed.

Do not touch cold metal parts with bare hands when operating under arctic conditions. Frostbite can cause permanent injury.

Do not allow fuel to come in contact with eyes or skin. Wear protective goggles. Fuels are toxic and can cause illness or death. If fuel contacts skin or eyes, flush and get medical attention immediately.

Do not spill fuel on clothing. Static electricity can ignite fuel and cause personnel injury or death. Remove clothing and wash affected area thoroughly and get medical attention immediately.

Do not breathe fuel vapors. Fuel vapors are toxic and can cause serious illness or death. If dizziness occurs, leave area and get fresh air.

Do not allow smoking within 100 feet of the dispensing area. Post NO SMOKING signs around the area. Avoid getting fuel on the body or clothing. If clothing becomes saturated with fuel, remove the clothing immediately and wash body with hot soapy water and soak clothing in soapy water. Avoid spillage of fuel. If spillage of fuel occurs, cover the area with dry soil to reduce the rate of vaporization. Make sure a suitable fire extinguisher is charged and readily available in case of fire.

Lifting or moving heavy equipment incorrectly can cause serious injury. Do not try to lift or move more than 50 pounds by yourself. Get an assistant. Bend legs while lifting. Do not support weight with your back.

Do not use excessive pressure when cleaning pipe or applying sealant onto nipple threads. Sharp thread edges can cause serious injury.

DO NOT breathe dry cleaning solvent vapors for long periods of time or allow solvent to come into contact with skin for an extended time. DO NOT use solvent near open flames or excessive heat.

FIRST AID instructions are given in FM 21-11, First Aid For Soldiers.

a /(b blank)

**OPERATOR'S AND UNIT MAINTENANCE MANUAL  
INCLUDING REPAIR PARTS AND SPECIAL TOOLS LIST**

**500 GALLON COLLAPSIBLE LIQUID FUEL DRUM,  
LOW TEMPERATURE**

**MODEL 91097  
(NSN: 8110-01-327-1981)**

**REPORTING ERRORS AND RECOMMENDING IMPROVEMENTS**

You can help improve this manual. If you find any mistakes, or if you know of a way to improve these procedures, please let us know. Mail your letter or DA Form 2028 (Recommended Changes to Publications and Blank Forms), or DA Form 2028-2 located in the back of this manual directly to: Commander, US Army Aviation and Troop Command, ATTN: AMSAT-I-MP, 4300 Goodfellow Blvd., St. Louis, MO 63120-1798. You may also submit your recommended changes by E-mail directly to <mpmP/oavma28@st-louis-emh7.army.mil>. A reply will be furnished directly to you. Instructions for sending an electronic 2028 may be found at the back of this manual immediately preceding the hard copy 2028.

Distribution Statement A. Approved for public release: distribution is unlimited.

**TABLE OF CONTENTS**

	<b>PAGE</b>
<b>HOW TO USE THIS MANUAL</b> .....	iii
<b>CHAPTER 1. INTRODUCTION</b>	
Section I. General Information .....	1-1
Section II. Equipment Description and Data .....	1-3
Section III. Principles of Operation .....	1-6
<b>CHAPTER 2. OPERATING INSTRUCTIONS</b>	
Section I. Description and Use of Operating Controls and Indicators .....	2-1
Section II. Operator Preventive Maintenance Checks and Services .....	2-1
Section III. Operation Under Usual Conditions.....	2-4
Section IV. Operation Under Unusual Conditions .....	2-7
<b>CHAPTER 3. OPERATOR MAINTENANCE INSTRUCTIONS</b>	
Section I. Lubrication Instructions .....	3-1
Section II. Operator Troubleshooting.....	3-1
Section III. Operator Maintenance Procedures .....	3-2
<b>CHAPTER 4. UNIT MAINTENANCE PROCEDURES</b>	
Section I. Repair Parts and Special Tools List .....	4-1
Section II. Service Upon Receipt .....	4-1
Section III. Preventive Maintenance Checks and Services .....	4-2
Section IV. Unit Troubleshooting .....	4-2
Section V. Unit Maintenance Procedures .....	4-4

**TABLE OF CONTENTS - continued**

<b>LIST OF APPENDICES</b>	<b>PAGE</b>
Appendix A References .....	A-1
Appendix B Maintenance Allocation Chart .....	B-1
Appendix C Unit Troubleshooting .....	C-1
Section I Introduction .....	C-1
Section II Repair Parts List .....	C-7
Section III. Special Tools List (Not Applicable) .....	C-9
Section IV. Cross-Reference Indexes .....	C-10
National Stock Number Index .....	C-11
Part Number Index .....	C-12
Figure and Item Index .....	C-13
Appendix D Components of End Item and Basic Issue Items List .....	D-1
Appendix E Additional Authorization List.....	E-1
Appendix F Expendable/Durable Supplies and Materials List.....	F-1
Appendix G Illustrated List of Manufactured Items .....	G-1
Appendix H Torque Limits .....	H-1
Glossary .....	Glossary 1
Index .....	Index

**LIST OF ILLUSTRATIONS**

Figure 1-1. 500 Gallon Drum .....	1-0
Figure 1-2. 500 Gallon Drum Major Components .....	1-4
Figure 1-3. Drum Principles of Operation .....	1-6
Figure 2-1. Operator PMCS Items .....	2-3
Figure 2-2. 500 Gallon Drum Decals and Instruction Plates .....	2-6
Figure 4-1. Installing Pipe Nipples and Adapters .....	4-2
Figure 4-2. Quick-Disconnect Adapter Removal .....	4-5
Figure 4-3. Quick-Disconnect Adapter Replacement.....	4-6
Figure 4-4. Shackles, Bearing, Swivel, and Closure Plate Replacement .....	4-8
Figure 4-5. Towing and Lifting Yoke .....	4-10
Figure C-1 500 Gallon Collapsible Liquid Fuel Drum .....	C-7
Figure D-1 Components of End Item .....	D-2
Figure D-2 Basic Issue Items List .....	D-3
Figure H-1 Torque Limits .....	H-1

**LIST OF TABLES**

Table 2-1 Operator Preventive Maintenance Checks and Services for 500 Gallon Collapsible Fuel Drum .....	2-3
Table 3-1 Operator Troubleshooting .....	3-2
Table 4-1 Unit Troubleshooting .....	4-3

## HOW TO USE THIS MANUAL

*Be sure to read all Warnings before using your equipment.*

This manual contains instructions for operation and maintenance of the 500 gallon fuel drum.

### MANUAL OVERVIEW

a. Index Tabs.

Notice the front cover index of this manual. It lists the most important areas of the manual and guides you to those sections. Follow the black mark on the cover index edge through the pages to the edge mark on the section you want. The subjects on the front cover index are also highlighted in the table of contents by boxes. A detailed alphabetical index is located at the back of this manual.

b. Contents.

The following gives you a summary of each chapter and appendix. Before beginning a maintenance task, you must familiarize yourself with the entire procedure.

- Chapter 1. Introduces you to the equipment and gives you information such as weight, dimensions, abbreviations used and information on how the unit works.
- Chapter 2. Provides information necessary to identify and use the equipment. Operating instructions in this chapter tell you how to use the equipment in both usual and unusual weather conditions. In addition, preventive maintenance instructions provide information needed to inspect and service the 500 gallon drum.
- Chapter 3. Provides operator troubleshooting procedures for identifying equipment malfunctions and maintenance procedures for performing operator maintenance tasks.
- Chapter 4. Provides unit maintenance personnel with troubleshooting procedures for identifying equipment malfunctions and maintenance procedures for repairing defective equipment.
- Appendix A. Provides a list of frequently used forms and publications referenced or used in this manual.
- Appendix B. The Maintenance Allocation Chart identifies repairable components and the maintenance level authorized to perform the repairs.
- Appendix C. The Repair Parts and Special Tools List (RPSTL) lists and authorizes the requisitioning, issue, and disposition of spares, repair parts and special tools as indicated by the source, maintenance and recoverability codes. This appendix also includes a cross reference index, nation stock number index, part number index and figure and item index which cross references national stock numbers and part numbers to each illustration, figure and item number.
- Appendix D. Lists components that are not mounted on the equipment, but are required to make the unit functional.
- Appendix E. List additional equipment authorized for your unit for use with the 500 gallon drum.
- Appendix F. Provides you with information about expendable supplies such as sealants, lubricants, chemicals etc. that are used when operating or maintaining the equipment.
- Appendix G. Provides a list of items and instructions on how to make certain tools and devices required to perform some of the maintenance tasks contained in this manual.
- Appendix H. Provides information concerning torque values and sequences required during maintenance of the equipment.
- Glossary. Lists terms and abbreviations used in this manual and their definitions.

**HOW TO USE THIS MANUAL continued**

- Index - Lists subject matter contained in manual in alphabetical order.

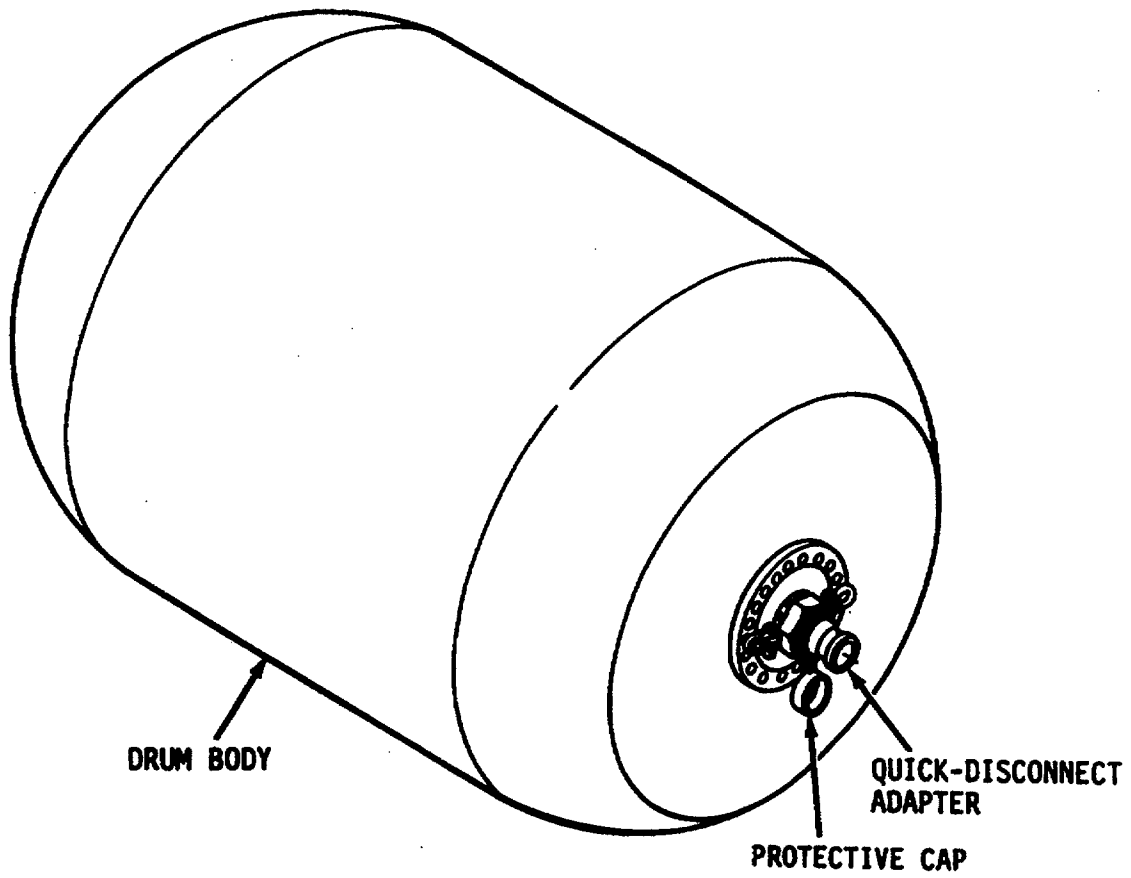

Figure 1-1. 500 Gallon Drum

(blank) /1-0

## CHAPTER 1 INTRODUCTION

---

### Section I. GENERAL INFORMATION

#### 1-1. SCOPE

This manual contains operating instructions, Unit maintenance procedures and Repair Parts and Special Tools List. These procedures are required to operate and maintain the 500 gallon drum, Model 91097.

The 500 gallon drum is a non-vented, cylindrical, collapsible drum for storing and transporting liquid fuels. The drum is designed for operation in environmental conditions including low ambient temperatures.

#### 1-2. MAINTENANCE FORMS AND PROCEDURES

Department of the Army forms and procedures used for equipment maintenance will be those prescribed by DA Pam 738-750, The Army Maintenance Management System (TAMMS) (Maintenance Management UPDATE).

#### 1-3. DESTRUCTION OF ARMY MATERIAL TO PREVENT ENEMY USE.

#### WARNING

**Fuels are hazardous flammable liquids. Avoid getting fuel on the body or clothing. Death or serious injury could occur if safety precautions are not strictly observed.**

- a. General This equipment may be destroyed by mechanical methods or by using the fuel which the drum contains to set it on fire.

#### NOTE

**Fuel in drum can be used to destroy other pieces of equipment in the same area**

- b. Mechanical Demolition. Use an axe, pick, mattock, sledge, or any other heavy implement to smash the quick disconnect adaptors and to slash holes in the drum.
- c. Demolition by Fire. Use some of the fuel contained in the drum to saturate the equipment and ignite.
- d. Additional Information. For additional information on procedure for destruction of materiel, refer to TM 750-244-3.



**1-4. CORROSION PREVENTION AND CONTROL.**

a. Corrosion Prevention and Control of Army Materiel is a continuing concern. It is important that any corrosion problems with this item be reported so that the problem can be corrected and improvements can be made to prevent the problem in future items.

b. While corrosion is typically associated with rusting of metals, it can also include deterioration of other materials, such as rubber and plastic. Unusual cracking, softening, swelling or breaking of the materials may be a corrosion problem.

c. If a corrosion problem is identified, it can be repaired using Standard om.368, Product Quality Deficiency Report. Using key words such as "rust", "deterioration", or "cracking" will insure that the information is identified as a CPC problem. The form should be submitted to the address specified in DA Pam 738-750.

**1-5. REPORTING EQUIPMENT IMPROVEMENT RECOMMENDATIONS (EIRs).**

If your 500 gallon drum needs improvement, let us know. Send us an EIR. You the user, are the only one who can tell us what you don't like about your equipment. Let us know why you don't like the design or performance. Put it on an SF 368 (Product Quality Deficiency Report). Mail it to us at: Commander, U.S. Army Aviation and Troop Command, ATTN: AMSAT-I-MDO, 4300 Goodfellow Boulevard, St. Louis, MO-63120-1798. We will send you a reply.

**1-6. NOMENCLATURE CROSSREFERENCE LIST.**

**Common Name**

500 Gallon Drum  
 Cylindrical, 500 Gallon Capacity, Low  
 Quick-disconnect Adapter

**Official Nomenclature**

Drum, Fabric, Collapsible, Liquid Fuel,  
 Temperature, Model 91097  
 Adapter, Quick- Dry

**1-7. LIST OF ABBREVIATIONS.**

Abbreviations, acronyms, signs or symbols used in this TM-are defined in the following table:

**Abbreviation, Acronym, of Symbol**

**Definition**

°F	Degrees Fahrenheit
CPC	Corrosion Prevention and Control
MPH	Miles per hour
NBC	Nuclear, Biological and Chemical
NSN	National Stock Number
P/N	Part Number
psig	Pound-force per Square Inch, Gage
RPSTL	Repair Parts and Special Tools List

**Section II. EQUIPMENT DESCRIPTION AND DATA'**

---

**1-8. EQUIPMENT CHARACTERISTICS, CAPABILITIES AND FEATURES.**

a. Fuel Drum. The 500 gallon drum, Model 91097 is a durable, non-vented, collapsible container that is designed for a working pressure of 4 to 5 psig (0.3 to 0.4 kg/sq. cm). The 500 gallon drum is intended for use at ambient temperatures between 60°F and +95°F (-50.6°C and +35.28°C) for the following:

- (1) Storage, receipt and issue of liquid fuel.
- (2) Transporting liquid fuel by:
  - (a) Truck.
  - (b) Aircraft
  - (c) Helicopter.
  - (d) Airdrop from fixed wing aircraft
  - (e) Towing as a wheel.

The drum fabric is impregnated with fuel resistant synthetic rubber. When filled to its 500 gallon (1893 liter) capacity, the drum is cylindrical in shape with rounded ends. It can be towed, at speeds not to exceed 10 mph (16 km/hr), for short distances over smooth terrain, using a towing and lifting yoke. The end closure plates are connected by three wire cables that provide interior support for the drum. Each closure plate is fitted with a quick-disconnect adapter. When the drum is collapsed, it can be folded to permit transportation by a cargo truck.

b. Accessory Items.

- (1) Towing and Lifting Yoke. A towing and lifting yoke can be attached to the ends of the 500 gallon drum for use in towing and lifting the drum.
- (2) Tie down Kit. A tie down kit is used to secure drums when they are being transported by cargo trucks.
- (3) Emergency Repair Kits. The repair kits are furnished for emergency use only to prevent leakage until the operator can empty the drum. When these kits are used to make such emergency repairs, the repaired drum should not be moved, towed, lifted or transported until it is completely empty.

## 1-9. LOCATION AND DESCRIPTION OF MAJOR COMPONENTS.

Major components of the 500 gallon drum are shown in figure 1-2.

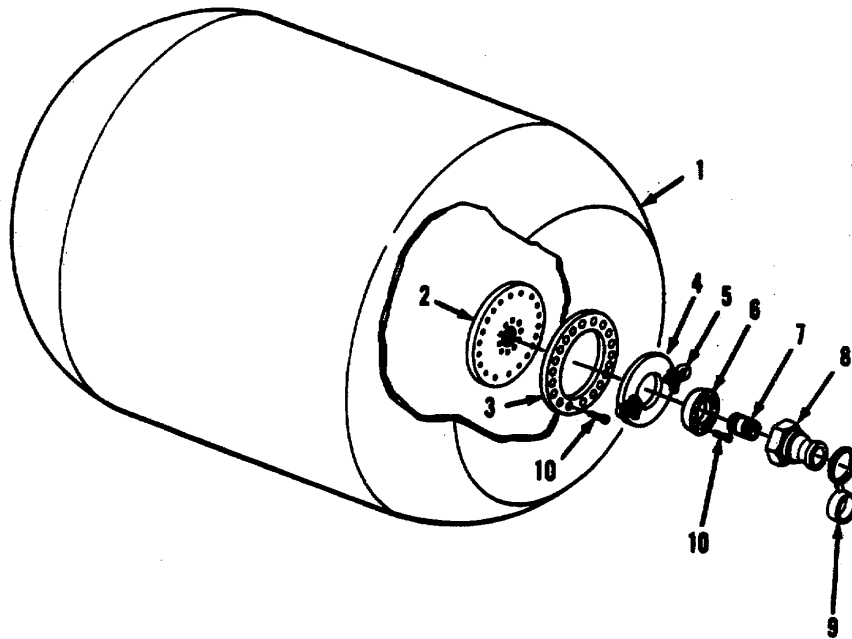

Figure 1-2. 500 Gallon Drum Major Components

- a. Drum Body. The drum body (1) is made of fuel resistant elastic material. The material is reinforced with fiber cords. The body contains the liquid fuel and provides protection during transport and storage.
- b. Closure Plate. Two internal closure plates (2), one at each end of the drum interior, provide a seal for the drum body. The plates are secured to external closure rings (3) by 21 screws (10). A threaded hole at the center of each closure plate mates with a pipe nipple (7) which mounts a quick-disconnect adapter (8).
- c. Closure Ring. The closure rings (3) provide an external sealing surface for the drum body (1). They are secured to the internal closure plate (2) with 21 cap screws (10).
- d. Swivel Plate. Two swivel plates(4), one at each end of the drum, provide a means for handling, lifting, and towing the drum. The ring mounts two shackles (5) on swivel plates(4). The ring is secured by the bearing plate (6) and closure ring (3). The swivel plate (4) rotates freely when the drum is towed.

**1-9. LOCATION AND DESCRIPTION OF MAJOR COMPONENTS - continued.**

- e. Bearing Plate. The bearing plate (6) secures the swivel plate (4) and provides a bearing surface for swivel plate (4) rotation. The bearing plate (6) is fastened to the closure plate (2) with 10 cap screws (10).
- f. Pipe Nipple. The pipe nipple (7) is a short section of threaded pipe. It connects the center hole of the closure plate (2) to the quick-disconnect adapter (8).
- g. Quick Disconnect Adapter. Two quick-disconnect adapters (8) are mounted on the 500 gallon drum. These are at each end, connected to the center of each closure plate (2) by pipe nipple (7). The adapters provide the drum fuel inlet/outlet.
- h. Protective Cap. A protective cap (9) is attached to each adapter (8) to cover it when not connected to a system.

**1-10. EQUIPMENT DATA.**

- a. General Information.

Model	91097
National Stock Number (NSN)	8110-01-327-1981
- b. Dimensions (Filled).

Length 63 inches (160 centimeters)	
Diameter	54 inches (137.1 centimeters)
Capacity	500 gallons (1892.5 liters)
- c. Weight

Empty 275 pounds (124.85 kilograms)	
Filled with fuel	3675 pounds(1668.45 kilograms)
- d. Operating Temperature Range:: -60°F to +95°F(-50.6°C to +35.28°C)
- e. Connections: Two 3-inch quick disconnect dry adapters

## Section III. PRINCIPLES OF OPERATION

## 1-11. SYSTEM TECHNICAL PRINCIPLES OF OPERATION.

The 500 gallon drum is a collapsible container for storing and transport liquid fuel. Materials used for the drum body are designed to allow handling, filling and emptying at temperatures from  $-60^{\circ}\text{F}$  to  $+95^{\circ}\text{F}$  ( $-50.6^{\circ}\text{C}$  to  $+35.28^{\circ}\text{C}$ ). The body is reinforced with polyester cord to withstand the stresses of handling and delivery. End to end drum stresses are limited by internal cables between the end plates. The fuel connections are quick disconnect adapters, one at each end of the drum. The adapter is of the dry type, which seals the connection when disconnected, preventing fuel spillage. The adapters are covered with protective caps when not in use.

Drum filling is by a pump to a safe internal pressure. The drum expands as it fills, and collapses as it is emptying. A filled drum can be lifted or towed on smooth terrain speeds not to exceed 10 mph (16km/hr) as a wheel. For these purposes a yoke assembly is fastened to both ends of the drum and to the lifting or towing device.

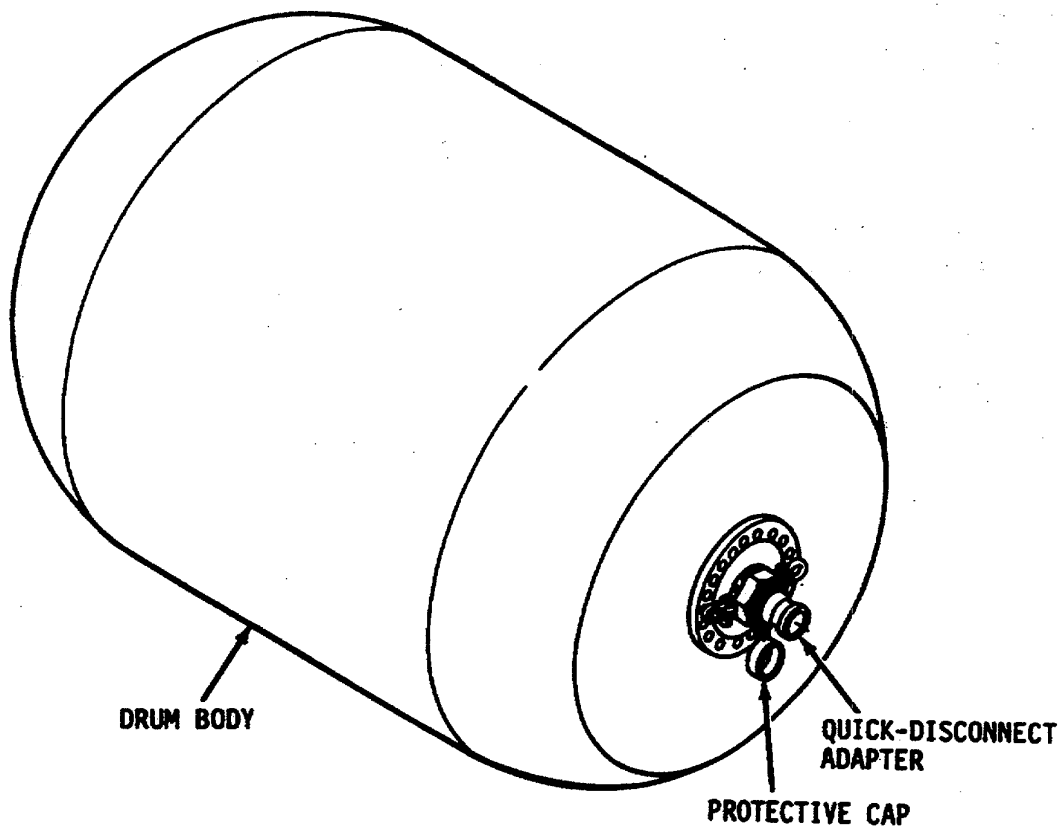

Figure 1-3. Drum Principles of Operation

**CHAPTER 2  
OPERATING INSTRUCTIONS**

<b>Paragraph</b>		<b>Page</b>
Section I	Description and Use of Operator's Controls and Indicators.....	2-1
Section II	Operator Preventive Maintenance Checks and Services.....	2-1
2-1.	General .....	2-1
2-2.	Warnings and Cautions.....	2-2
2-3.	Leakage Definitions for Operator PMCS .....	2-2
2-4.	Explanation of Table Entries.....	2-2
Section III	Operation Under Usual Conditions.....	2-4
2-5.	Assembly.....	2-4
2-6.	Operating Procedures.....	2-4
2-7.	Decals and Instruction Plates.....	2-6
Section IV	Operation Under Unusual Conditions.....	2-7
2-8.	Unusual Environmental/Weather Conditions.....	2-7
2-9.	Emergency Procedures .....	2-8
2-10.	Nuclear, Biological and Chemical (NBC) Decontamination Procedures.....	2-8

**Section I. DESCRIPTION AND USE OF OPERATING CONTROLS AND INDICATORS**

The 500 gallon drum has no operating controls or indicators.

**Section II. OPERATOR PREVENTIVE MAINTENANCE CHECKS AND SERVICES**

**2-1. GENERAL.**

- a. To ensure that the drums are ready for use at all times, they must be inspected systematically so that defects may be discovered and corrected before they result in serious damage or failure of equipment. The necessary preventive maintenance checks to be performed are listed and described in Table 2-1.
- b. Defects discovered during operation of the unit shall be noted for future correction, to be made as soon as the operation has ceased.
- c. Stop operation immediately if a deficiency is noted during operation which would damage the equipment or result in personal injury if operation were continued.

- d. Keep the equipment clean. Remove dirt, sand and debris from quick-disconnect adapters to prevent excessive wear and contamination. Use soap and water to remove dirt.
- e.. All deficiencies and short comings will be recorded, together with the corrective action taken, on DA Form 2404 (Equipment Inspection and Maintenance Worksheet) at the earliest possible opportunity.

## **2-2. WARNINGS AND CAUTIONS.**

Always keep in mind the CAUTIONS and-WARNINGS.

## **2-3. LEAKAGE DEFINITIONS FOR OPERATOR PMCS.**

It is necessary for you to know how fluid leakage affects the status of the equipment. Following are types/classes of leakage an operator needs to know to be able to determine the status of the equipment. Learn these, leakage definitions and remember -when in doubt, notify your supervisor.

### **CAUTION**

**Leaks should be reported immediately to your supervisor.**

- a. CLASS I. - Seepage of fluid (as indicated by wetness or discoloration) not great enough to form drops.
- b. CLASS II. - Leakage of fluid great enough to form drops but not enough to cause drops to drip from item being checked /inspected
- c. CLASS III. - Leakage of fluid great enough to form drops that fall from item being checked/inspected.

## **2-4. EXPLANATION-OF TABLE ENTRIES.**

Table 2-1 contains a tabulated listing of preventive maintenance checks and services which must be performed by the operator. illustrations are provided to identify the items.

**Table 2-1. Operator Preventive Maintenance Checks and Services for 500 Gallon Collapsible Fuel Drum.**

Note: Within designated interval these checks are to be performed in the order listed.

Item No.	Interval	Location Item to Check/ Service	Procedure	Not Fully Mission Capable if:
1	Before	500 Gallon Drum Body	Check the drum (1) for cuts, holes, deterioration and leaks. Check the metal parts for cracks, leaks, and loose screws.	Leak found.
2	Before	Quick-Disconnect Adapters	Check both adapters (2) for damage, cracks or leaks.	Leak or damage found.
3	Before	Swivel Plates	Check swivel plates (3) for free rotation and missing/damaged shackles.	Swivel plates (3) do not move freely or shackles missing or damaged.
4	During	500 Gallon Drum Body	Check drum (1) for leaks.	Leak found.
5	During	Quick-Disconnect Adapters	Check both adapters (2) for damage, cracks or leaks.	Leak or damage found.
6	After	500 Gallon Drum Body	Check drum (1) for leaks.	Leak found.
7	After	Quick-Disconnect Adapters	Check both adapters (2) for damage, cracks or leaks.	Leak or damage found.

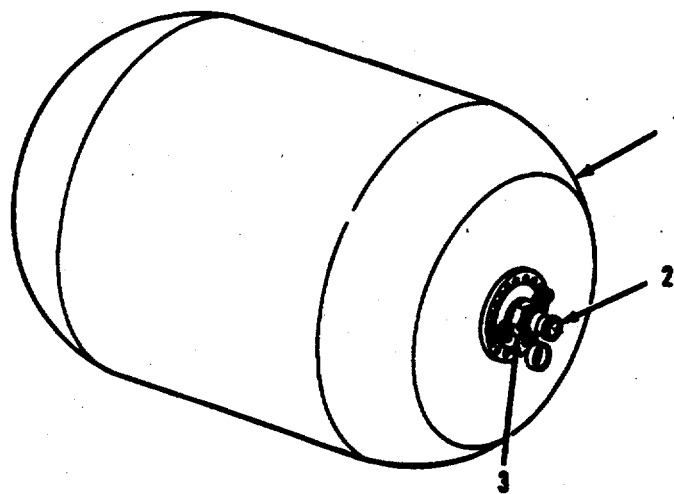

**Figure 2-1. Operator PMCS Items**



---

**Section III. OPERATION UNDER USUAL CONDITIONS****2-5. ASSEMBLY.**

The 500 gallon drum requires no assembly. An emergency Type I Repair Kit (Appendix E) is required when drum is in use.

**2-6. OPERATING PROCEDURES.****a** Filling the 500 gallon drum.

- (1) Remove the protective cap from the quick-disconnect adapter to be

**WARNING**

**Be certain the drum is secure to avoid slipping or rolling during filling operation. Avoid spillage of product. If spillage occurs, cover the area with dry soil to reduce its rate of vaporization. Avoid getting product on body or clothing. If clothing becomes saturated with fuel remove the clothing immediately and wash body with hot soapy water. Do not allow smoking within 100 feet of the filling area. Be certain a suitable fire extinguisher is present.**

- (2) Connect the fuel supply coupler to the 500 gallon drum quick disconnect adapter.
- (3) Fill drum.

**b.** Transporting the 500 gallon drum when filled

- (1) Unfold the towing and lifting yoke and connect the two braces.
- (2) Install two screws and lock nuts to secure the braces together.
- (3) Place ends of towing arms into position onto towing pins of collapsible drum assembly.
- (4) Insert clevis pins through the towing yoke arms and through towing pins on each side of collapsible drum assembly.

**CAUTION**

**Sharp objects or rough terrain can seriously damage the collapsible drum. Do not tow the collapsible drum over sharp objects or rough terrain. Do not tow the collapsible drum at speeds greater than 10 mph.**

- (5) Tow the collapsible drum into position.
- (6) Remove clevis pins from towing yoke arms and from towing pins of the collapsible drum assembly.

**2-6. OPERATING PROCEDURES - continued.**

- (7) Remove two lock nuts and screws connecting the braces.
- (8) Fold braces together and store towing and lifting yoke away for future use.

## c. Emptying the drum.

**WARNING**

**Do not allow smoking within 100 feet of the dispensing area. Post NO SMOKING signs around the area. Avoid getting fuel on the body or clothing. If clothing becomes saturated with fuel, remove the clothing immediately and wash body with hot soapy water and soak clothing in soapy water. Avoid spillage of fuel. If spillage of fuel occurs, cover the area with dry soil to reduce the rate of vaporization. Be certain a suitable fire extinguisher is present and that it is properly charged and positioned so as to be readily available in case of fire.**

- (1) Place drum in position for operation
- (2) Remove the protective cap from the drum quick-disconnect adapter.
- (3) Connect the fuel system to the 500 gallon drum quick-disconnect adapter.

## d. Preparing the 500 gallon drum for transit when empty.

- (1) Remove any residual fuel from the drum while connected to the system.
- (2) Disconnect the fuel system coupler from the drum quick disconnect adapter.
- (3) Place the protective cap on the adapter.

**WARNING**

**Lifting or moving heavy equipment incorrectly can cause serious injury. Do not try to lift or move more than 50 pounds by yourself. Always use assistants during lifting operations. Bend legs while lifting. Do not support heavy weight with your back**

- (4) Fold the empty drum and place on a suitable carrier.

2-7. DECALS AND INSTRUCTION PLATES.

- a. The word FLAMMABLE is marked on the ends of the 500 gallon drum body.
- b. On each end closure ring, the legend DO NOT USE FOR WATER STORAGE is marked.

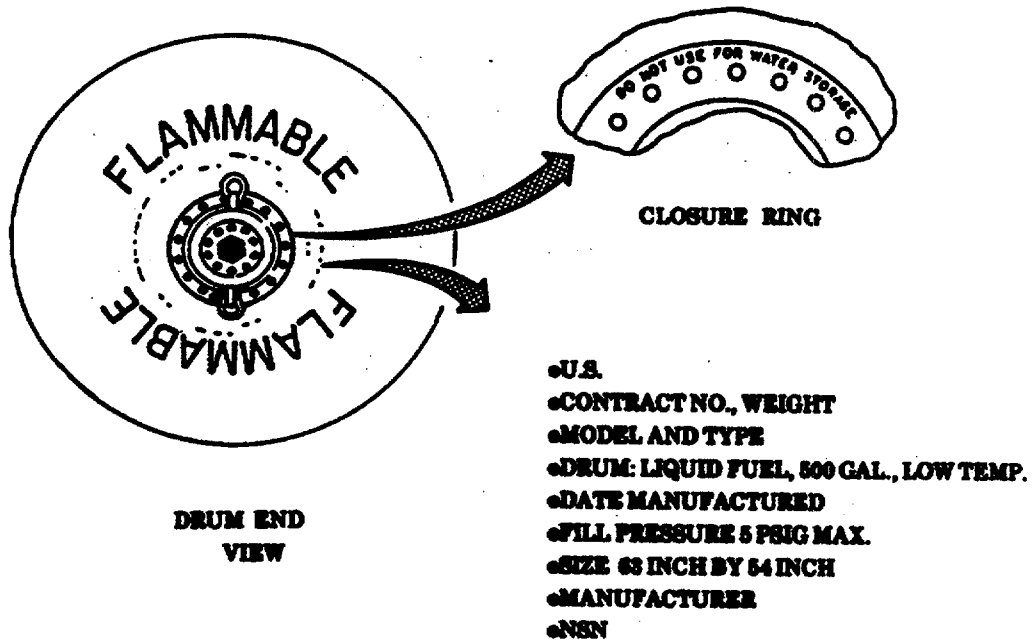

Figure 2-2. 500 Gallon Drum Decals and Instruction Plates.

**Section IV. OPERATION UNDER UNUSUAL CONDITIONS****2-8. UNUSUAL ENVIRONMENTAL/WEATHER CONDITIONS.**

- a. Operating the 500 Gallon Drum in Arctic Cold Conditions.

**WARNING**

**Do not touch cold metal parts with bare hands when operating under arctic cold conditions. Frostbite can cause permanent injury.**

- (1) Be careful when handling the hose assembly and drum to avoid cracking them. Always wear arctic mittens when handling nozzles and other equipment.
- (2) Remove snow, sleet, or ice from the drum before connecting the coupler to drum adapter.
- (3) Perform operating procedure according to paragraph 2-6.

- b. Operating the 500 Gallon Drum in Extreme Heat.

To keep the drum as cool as possible, proceed with one or more of the following steps, as applicable to the location

- (1) Erect a tent or tarpaulin over the drum but do not block the circulation of air around the drum.
- (2) Place the drum under shade of trees or cover it with leafy branches.
- (3) Cover the drum with wet burlap or other fabric, and keep the drum wet.

**CAUTION**

**In extreme high temperatures, it may be necessary to reduce the amount of fuel in the drum to allow for expansion.**

- (4) Perform operating procedure according to paragraph 2-6.

- c. Operating the 500 Gallon Drum in Strong Winds And Sandy or Dusty Conditions.

- (1) Strong Winds.
  - (a) Anchor the drum by banking soil around the sides.
  - (b) Anchor the drum to the ground with ropes and stakes.

**2-8. UNUSUAL ENVIRONMENTAL/WEATHER CONDITIONS - continued**

(2) Sandy and Dusty Conditions.

- (a) Remove any sand or dust from the quick-disconnect adapter before installing a coupler on the drum.
- (b) Keep protective caps installed on adapters when the drum is not in use.

(3) Perform operating procedure according to paragraph 2-6.

**2-9. EMERGENCY PROCEDURES.**

**WARNING**

**Do not allow fuel to come in contact with eyes or skin. Wear protective goggles. Fuels are toxic and can cause illness or death. If fuel contacts the skin or eyes, flush and get medical attention immediately.**

a. During Operation.

(1) If spillage of fuel occurs, cover the areas with dry soil to reduce its rate of vaporization.

(2) If, drum is punctured, repair drum per instructions provided in the Emergency Repair Kit, Type I (Appendix E).

b. After Operation.

(1) When emergency kit is used to make repairs, the repaired drum must not be moved, towed, lifted or transported until it is completely empty.

(2) As soon as practical after the drum has been emptied, it should be moved to the appropriate maintenance repair facility.

**2-10. NUCLEAR, BIOLOGICAL, AND CHEMICAL (NBC) DECONTAMINATION PROCEDURES.**

**NOTE**

**Detailed decontamination procedures can be found in FM3-3, FM3-4, and FM3-5.**

a. General. The following emergency procedures can be followed until field NBC decontamination facilities are available. Assigned operators will assist the supporting NBC unit.

**2-10. NUCLEAR, BIOLOGICAL, AND CHEMICAL (NBC) DECONTAMINATION PROCEDURES - CONTINUED**

b. Emergency Procedure. If NBC attack is known or suspected, mask at once and perform the following:

- (1) Stop dispensing of fuel.
- (2) Do not connect or disconnect the 500 gallon drum to or from the fuel system.
- (3) Have fuel tested for contamination before resuming operation

**2-9 / (2-10 blank)**

**CHAPTER 3  
OPERATOR MAINTENANCE INSTRUCTIONS**

<b>Paragraph</b>		<b>Page</b>
<b>Section I</b>	<b>Lubrication Instructions</b>	3-1
<b>Section II</b>	<b>Operator Troubleshooting</b>	3-1
3-1.	Introduction	3-1
3-2.	Troubleshooting	3-2
<b>Section III</b>	<b>Operator Maintenance Procedures</b>	3-2
3-3.	Emergency Repair Procedures	3-2

**Section I. LUBRICATION INSTRUCTIONS**

Lubrication is not required for the 500 gallon drum.

**Section II. OPERATOR TROUBLESHOOTING**

**3-1. INTRODUCTION.**

a. This section contains troubleshooting information for locating and correcting most of the operating trouble which may develop in the 500 gallon drum and its components. Each malfunction is followed by a list of tests or inspections which will help you to determine probable causes and corrective actions to take.

b. This manual cannot list all malfunctions that may occur, nor all tests or inspections and corrective actions. If a malfunction is not listed or is not corrected by listed corrective actions, notify your supervisor.

c. Table 3-1 lists the common malfunctions which you may find during the operation or maintenance of the 500 gallon drum. You should perform the tests/inspections and corrective actions in the order listed.

**3-2. TROUBLESHOOTING.**

Refer to Table 3-1 for troubleshooting procedures applicable to the drum. Any trouble requiring repair beyond the scope of the operator should be referred to unit maintenance.

**Table 3-1. Operator Troubleshooting**

<b>MALFUNCTION</b>	<b>TEST OR INSPECTION</b>	<b>CORRECTIVE ACTION</b>
1. Drum Body Leaks.		<p>Check for cuts, worn spots, or punctures.</p> <p>Perform emergency repair procedures per paragraph 3-3 and notify unit maintenance for repair.</p>
2. Quick-Disconnect Adapter Leaks.		<p>Check for looseness.</p> <p>Hand-tighten as required. If still leaks, notify unit maintenance for repair.</p>

**Section III. OPERATOR MAINTENANCE PROCEDURES**

**3-3. EMERGENCY REPAIR PROCEDURES.**

If drum is punctured, repair drum per instructions provided in the Emergency Repair Kit, Type I (Appendix E).



**CHAPTER 4  
UNIT MAINTENANCE PROCEDURES**

---

**Section I. REPAIR PARTS AND SPECIAL TOOLS LIST**

**4-1. COMMON TOOLS AND EQUIPMENT.**

For authorized common tools and equipment refer to the Modified Table of Organization and Equipment (MTOE) applicable to your unit.

**4-2. SPECIAL TOOLS, TMDE, AND SUPPORT EQUIPMENT.**

Refer to the Maintenance Allocation Chart contained in Appendix B for maintenance tasks authorized at unit level and for the TMDE and support equipment required to perform these tasks.

**4-3. REPAIR PARTS.**

Repair parts are listed and illustrated in Appendix C - Repair Parts and Special Tools List (RPSTL).

---

**Section II. SERVICE UPON RECEIPT**

**4-4. SERVICE UPON RECEIPT.**

**WARNING**

**Lifting or moving heavy equipment incorrectly can cause serious injury. Do not try to lift or move more than 50 pounds by yourself. Get an assistant. Bend legs while lifting. Do not support weight with your back.**

- a. Remove drum from container. Refer to Figure 4-1.
- b. Position drum so end plates are accessible.

**WARNING**

**Do not use excessive pressure when applying sealant onto nipple threads. Sharp thread edges can cause serious injury.**

- c. Apply sealant provided with drum to threads on pipe nipple (1) and install into adapter (2).
- d. Install adapter and nipple into closure plate (3).

**CAUTION**

**Hand-tighten adapter and nipple into closure plate. Over-tightening could strip threads.**

**4-4. SERVICE UPON RECEIPT - continued.**

- e. Position drum for access to other closure plate and flatten drum body to remove air from drum.
- f. Repeat steps c and d at other end of drum.
- g. Place protective caps (4) on adapters (2).

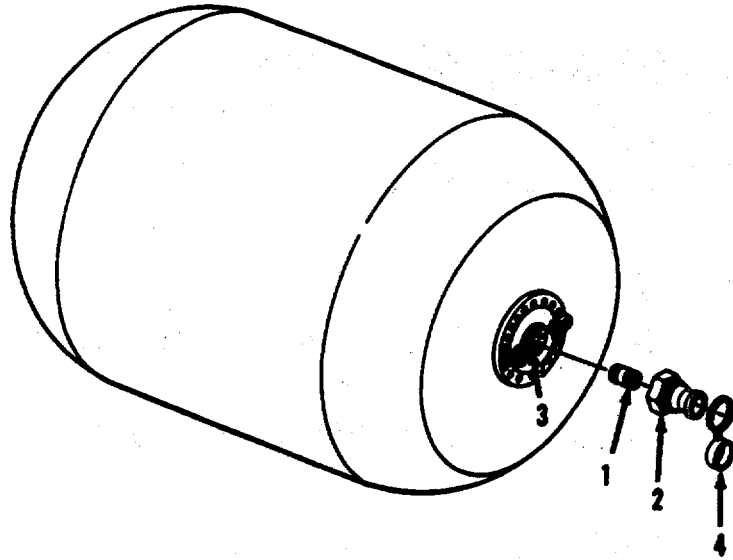

**Figure 4-1. Installing Pipe Nipples and Adapters**

---

**Section III. PREVENTIVE MAINTENANCE CHECKS AND SERVICES**

There are no unit preventive maintenance checks and services for the 500 gallon drum.

---

**Section IV. UNIT TROUBLESHOOTING PROCEDURES**

**4-5. INTRODUCTION.**

a. This section contains troubleshooting information for locating and correcting most of the operation troubles which may develop in the drum. Each malfunction is followed by a test or inspection which will help you to determine corrective actions to take.

b. This manual cannot list all malfunctions that may occur, nor all tests or inspection and corrective actions. If a malfunction is not listed or is not corrected by listed corrective actions, notify your supervisor.

c. Table 4-1 lists common malfunctions which you may find during the operation or maintenance of the drum and its components. You should perform the tests/inspections and corrective actions in the order listed.

**4-6. TROUBLESHOOTING.**

Refer to Table 4-1 for troubleshooting procedures applicable to the drum.

**Table 4-1. Unit Troubleshooting**

<b>MALFUNCTION</b>	<b>TEST OR INSPECTION</b>	<b>CORRECTIVE ACTION</b>
1. Drum Body Leaks.	Inspect for loose screws on closure plate.	Re-torque screws to 45 foot pounds.
2. Quick-disconnect Adapter Leaks.	Inspect for damage.	If required, replace quick-disconnect adapter.
3. Pipe nipple leaks.	Inspect for damage.	If required, replace pipe nipple.

**Section V. UNIT MAINTENANCE PROCEDURES**

**4-7. GENERAL.**

This section contains instructions for performing unit level maintenance on the 500 gallon drum.

**4-8. PERSONNEL SAFETY.**

To ensure safety of personnel, proper care should be used when handling assemblies and parts. Many assemblies are heavy. The assistance of another person, lifting device, or other support equipment may be required to move or position heavy items.

Personnel must remove all items of jewelry (rings, bracelets, watches, necklaces, etc.) and loose clothing before working on the equipment. Jewelry and loose clothing can get caught in moving equipment and result in injury to personnel.

When performing maintenance on the 500 gallon drum, keep in mind that the purpose of the equipment is to store and distribute fuel. Cleaning fluids, lubricants, preservatives, paint or other chemicals must not be allowed to contaminate the fuel.

Operate the equipment after performing maintenance to ensure repairs have been performed correctly and equipment can be returned to service.

**4-9. PROPER EQUIPMENT.**

Obtain proper equipment before beginning maintenance. This includes hand tools and/or special tools, receptacles for storing small parts, and expendable materials required by the maintenance task.

**4-10. REPLACE QUICK-DISCONNECT ADAPTER.**

This task covers: (a) removal (b) installation

<b>INITIAL SETUP</b>
<p><u>Tools:</u>                      Tool Kit, General Mechanics: (Item 1, Appendix B, Section III)                      Strap Wrench: (Item 2, Appendix B, Section III)</p> <p><u>Equipment Condition:</u>                      Drum empty (para 2-6)</p> <p><u>Materials/Parts:</u>                      Sealant, Thread: (Item 1, Appendix F Section I)                      Rags, Wiping: (Item 2, Appendix F Section II)</p>

## 4-10. REPLACE QUICK-DISCONNECT ADAPTER - continued.

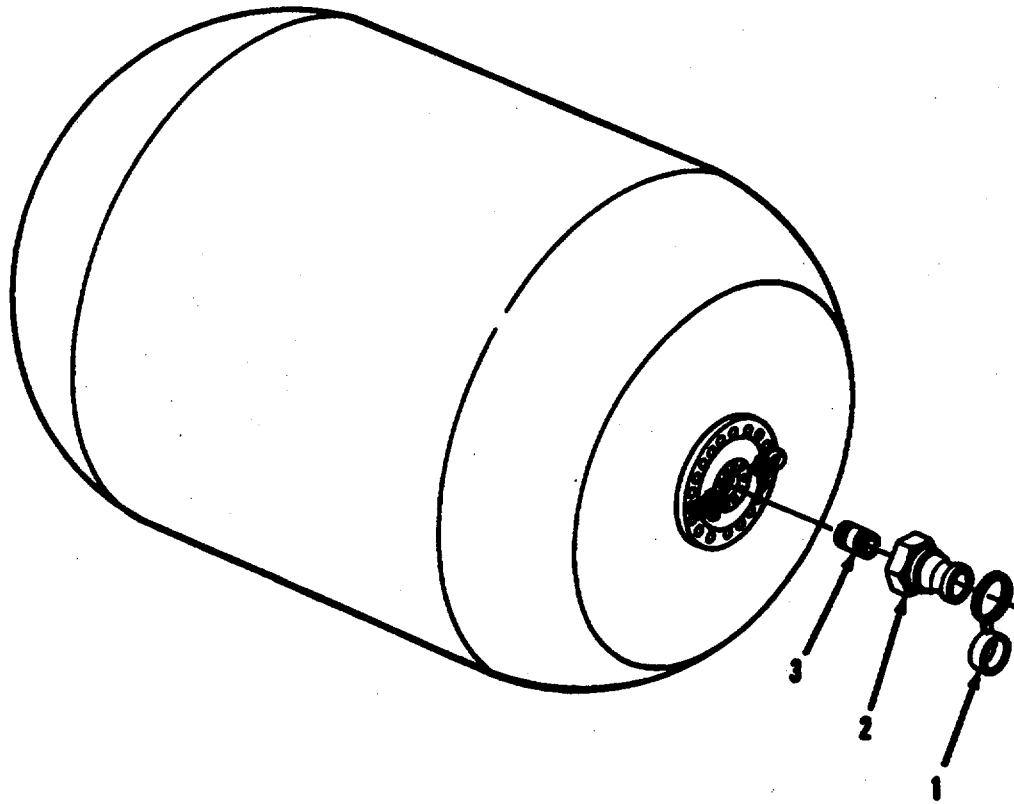

Figure 4-2. Quick-Disconnect Adapter Removal

## a. Removal

1. Remove the protective cap (1) from the quick-disconnect adapter (2).

**NOTE**

**If the pipe nipple comes out with the quick-disconnect adapter, it will need to be replaced as well.**

2. Remove the quick disconnect adapter (2) from the pipe nipple (3) at the dram end.

## 4-10. REPLACE QUICK-DISCONNECT ADAPTER - continued.

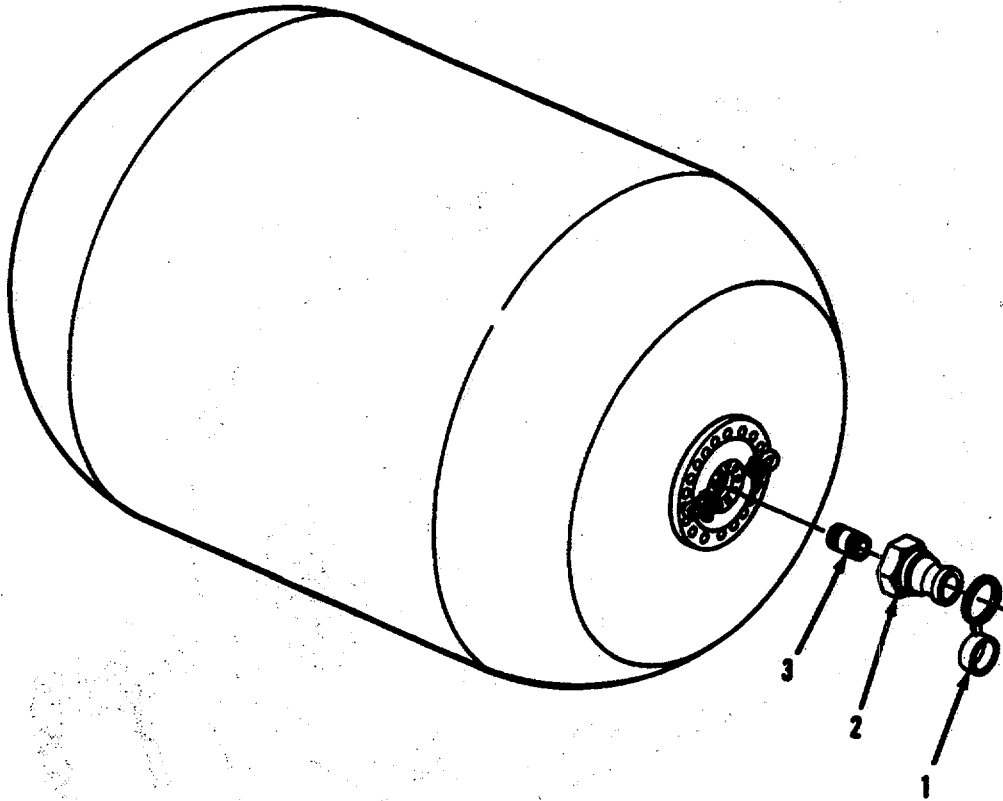

Figure 4-3. Quick-Disconnect Adapter Replacement.

b. Installation.**WARNING**

Do not use excessive pressure when cleaning pipe nipple threads. Sharp threads can cause serious injury.

1. Clean the threads of the pipe nipple (3).

**WARNING**

Do not use excessive pressure when or applying sealant onto pipe nipple threads. Sharp threads can-cause serious injury.

2. Apply a coating of thread sealant on the pipe nipple(3) threads.
3. Install the quick-disconnect adapter (2) on the pipe nipple (3).
4. Place the protective cap (1) on the quick disconnect adapter (2).

**4-11. REPLACE SHACKLES, BEARING, SWIVEL AND CLOSURE PLATES.**

This task covers: (a) removal (b) inspections (c) service (d) installation

<b>INITIAL SETUP</b>
<p><b><u>Tools</u></b>                      Tool Kit, General Mechanics: (Item 1, Appendix B, Section III)                      5/16 Inch Socket, Socket Wren (Item 2, Appendix B, Section II)                      Torque Wench: (Item 2, Appendix B, Section III)                      Equipment Condition:                      Quick disconnect adapter removed (para 4- 10)</p> <p><b><u>Materials/Parts:</u></b>                      Cotter Pin: (Appendix C, Section II)</p>

a. Removal (refer to figure 44)

1. Remove cotter pins (1) from shackle pins (2).
2. Remove shackle pins (2) from tab on swivel plate (6).
3. Remove shackles (3).
4. Unscrew ten screws(4) from bearing plate (5).
5. Remove bearing plate (5) and swivel plate(6).

b. Inspection

1. Check for loose screws (7) on closure rings (8). If loose, tighten to 45 foot pounds.
2. Inspect for corrosion on bearing plate (5) and swivel plate (6).
3. Inspect shackles (3) and shackle pins (2) for damage.

c. Service

Clean all removed parts with wiping rags.

d. Installation

1. Install swivel plate (6) on closure plate.
2. Install bearing plate (5) inside swivel plate (6) and secure with ten screws (4). Tighten screws(4) to 45 foot pounds.
3. Mount shackles (3) to tabs on swivel plate (6) with shackle pins (2).

4-11. REPLACE SHACKLES, BEARING, SWIVEL AND CLOSURE PLATES - continued.

4. Install new cotter pins (1) in shackle pins (2).

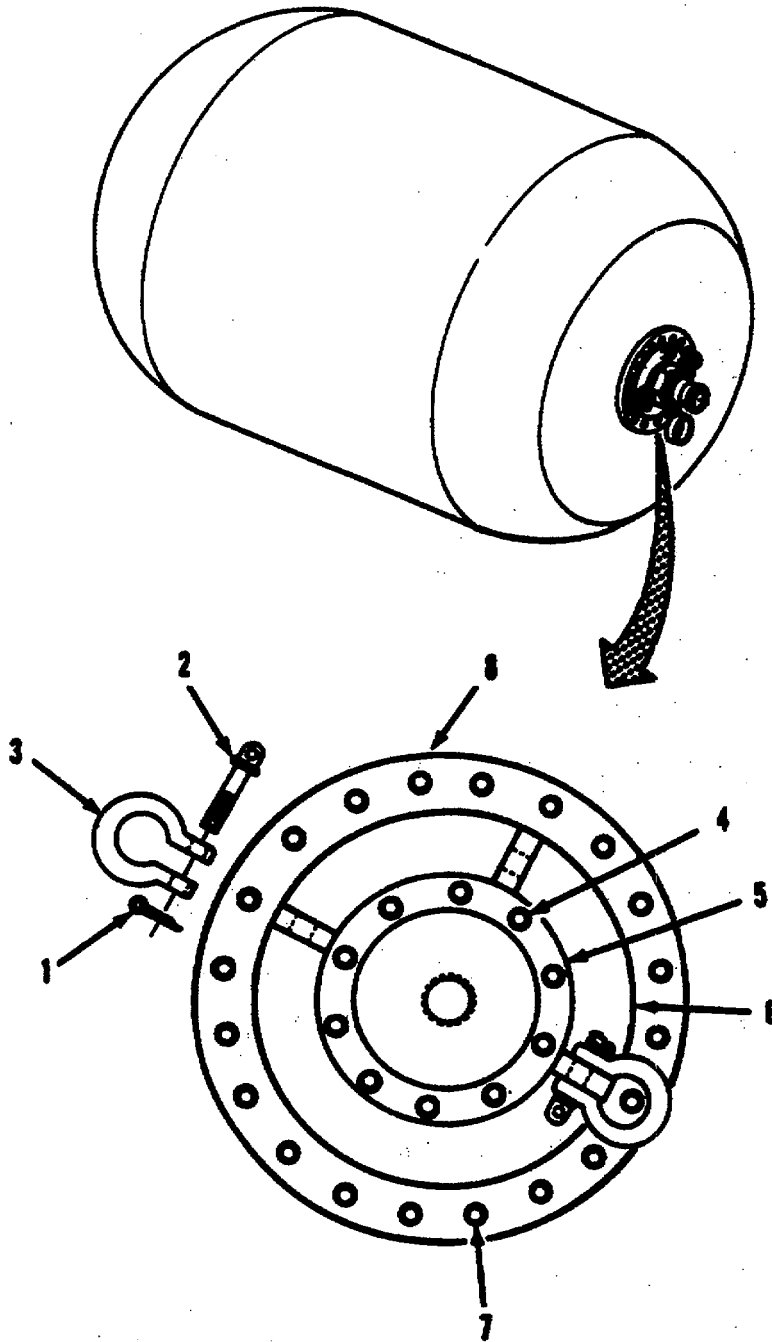

Figure 4-4. Shackles, Bearing, Swivel, and Closure Plate Replacement.



**4-12. REPAIR TOWING AND LIFTING YOKE.**

This task covers: (a) disassembly (b) cleaning (c) inspection (d) assembly

**INITIAL SETUP**

Tools:

Tool Kit, General Mechanics: ( Item 1, Appendix B, Section III)

Equipment Condition:

Towing and Lifting Yoke removed from drum.

Materials/Parts:

Dry cleaning Solvent (Item 3, Appendix F, Section II)

Rag, wiping: (Item 2 Appendix F, Section II )

(Refer to Figure 4-4).

**NOTE**

**Repair is limited to replacement of parts found defective during inspection.**

a. Disassembly

1. Remove two s-hooks (1) and two clevis pin assemblies (2).
2. Remove two screws (3) and two lock nuts (4) from braces (5).
3. Remove two screws (6) and two lock nuts (7) and then remove two braces (5) from two connecting legs (8).
4. Remove two set screws (9) and two pins (10) and then remove two connecting legs (8) from two upper legs (11).

b. Cleaning

1. Remove all buildup of dirt, oil and debris from all mating surfaces.

**WARNING**

**DO NOT breathe dry cleaning solvent vapors for long periods of time or allow solvent to come into contact with skin for an extended time. DO NOT use solvent near open flames or excessive heat.**

2. Clean all metallic parts with a clean wiping rag (Item 2 Appendix F and cleaning solvent (Item 3. Appendix F) and allow parts to dry.

#### 4-12. REPAIR TOWING AND LIFTING YOKE- continued

##### c. Inspection.

Inspect all metal parts for cracks, corrosion, or broken fittings.

##### d. Assembly.

1. Place two upper legs (11) onto two connecting legs (8) and install two pins (10) and two set screws (9).
2. Place two braces (5) onto two connecting legs (8) and install two lock nuts (7) and two screws (6).
3. Install two lock nuts (4) and two screws (3) into two braces (5).
4. Install two clevis pin assemblies (2) and two s-hooks (1) onto connecting legs (8).

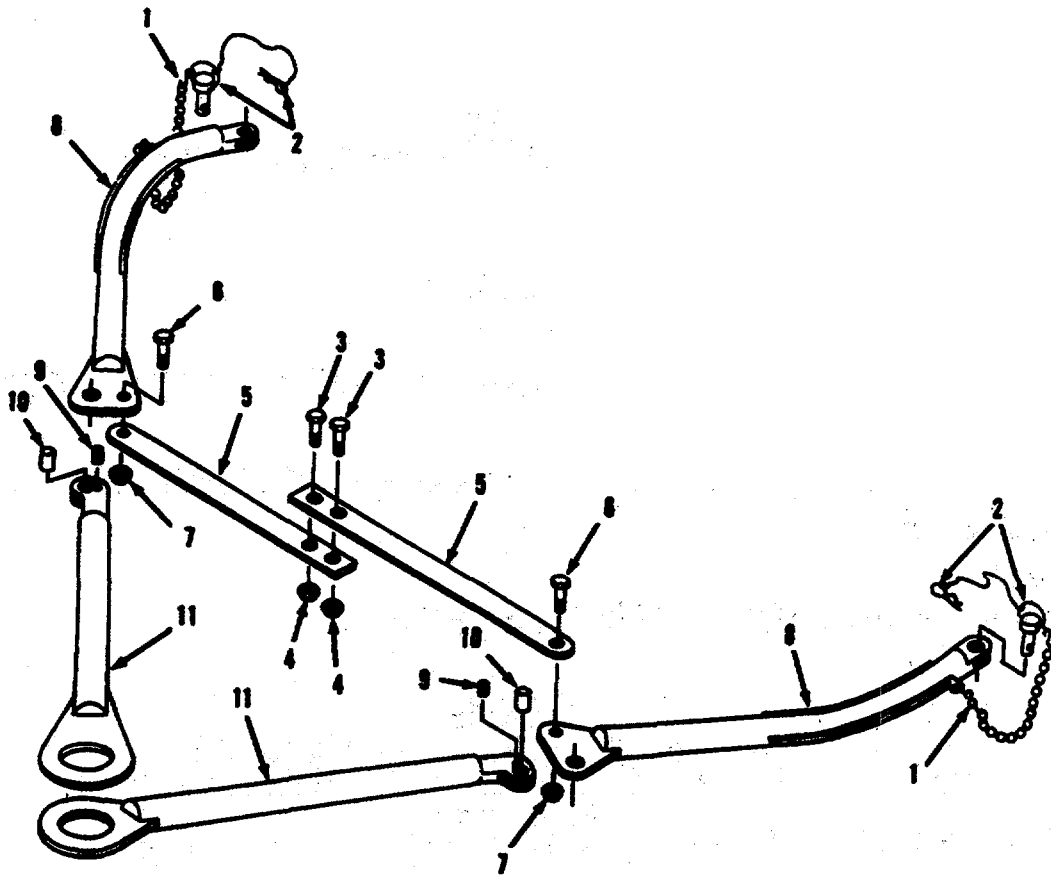

Figure 4-5. Towing and Lifting Yoke.

**Section VI. PREPARATION FOR STORAGE OR SHIPMENT**

**4-13. SECURITY PROCEDURES.**

Refer to AR 190-11 or AR 190-13.

**4-14. PREPARATION FOR MOVEMENT.**

- a. Towing the Drum. A filled drum can be moved for short distances at speeds not to exceed 10 mph by towing with a vehicle. A towing and lifting yoke is required for towing. Refer to TM 10-8110-201-14&P.
- b. Moving by Truck. Filled drums may be loaded onto cargo trucks for moving. Be sure all objects are removed from the cargo area before loading. A towing and lifting yoke as well as a lifting device of suitable capacity are required for loading. Drums must be secured in place by chains to the truck cargo area Refer to TM 10-8110201-14&P.
- c. Transporting by Aircraft. Rigging, loading and dropping procedures to be followed are given in FM 10-564.

**4-15. ADMINISTRATIVE STORAGE.**

Placement of equipment in administrative storage should be for short periods of time when a shortage of maintenance effort exists. Items should be in mission readiness within 24 hours or within the time factors as determined by the directing authority. During the storage period, appropriate maintenance records will be kept.

Before placing the equipment in administrative storage, current preventive maintenance checks and services should be completed, shortcomings and deficiencies should be corrected, and all Modification Work Orders (MWO) should be applied.

Storage site selection. Inside storage is preferred for items selected for administrative storage. If inside storage is not available, trucks, vans, convex containers, and other containers may be used.

**4-11 /(4-12 blank)**

APPENDIX A

REFERENCES

**A-1. SCOPE**

This appendix lists all forms, field manuals, technical manuals, and miscellaneous publications referenced in this manual.

**A-2. FORMS**

Recommended Changes to DA Publications .....	DA Form 2028-2
Recommended Changes to DA Publications and Blank Forms .....	DA Form 2028
Equipment Inspection and Maintenance Worksheet .....	DA Form 2404
Maintenance Request .....	DA Form 2407
Product Quality Deficiency Report .....	STD Form 368

**A-3. FIELD MANUALS**

First Aid for Soldiers .....	FM 21-11
NBC Decontamination Procedures .....	FM 3-3, FM 3-4, FM 3-5
Rigging, Loading and Dropping Procedures .....	FM 10-564
Basic Cold Weather Manual .....	FM 31-70
Northern Operations .....	FM 31-71

**A-4. TECHNICAL MANUALS**

Destruction of Army Material to Prevent Enemy Use .....	TM 750-244-3
Drums, Fabric, Collapsible, Non-Vented .....	TM 10-8110-201-14&P

**A-5. MISCELLANEOUS**

The Army Maintenance Management System .....	DA PAM 738-750
Safety Procedures .....	AR 190-11, AR 190-13

**APPENDIX B**  
**MAINTENANCE ALLOCATION CHART**

---

**Section I. INTRODUCTION**

**B-1. GENERAL.**

a. This section provides a general explanation of all maintenance and repair function authorized at various maintenance categories.

b. The Maintenance Allocation Chart (MAC) in Section II designates overall authority and responsibility for performance of maintenance functions on the identified end item or component. The application of the maintenance functions to the end item or component will be consistent with the capacities and capabilities of the designated maintenance categories.

c. Section III lists the tools and test equipment (both special tools and common tool sets) required for each maintenance function as referenced from Section II.

d. Section IV contains supplemental instructions and explanatory notes for a particular maintenance function.

**B-2. MAINTENANCE FUNCTIONS.**

Maintenance functions will be limited to and are defined as follows:

a. Inspect. To determine the serviceability of an item by comparing its physical, mechanical, and/or electrical characteristics with established standards through examination (e.g., by sight, sound, or feel).

b. Test. To verify serviceability by measuring the mechanical, pneumatic, hydraulic, or electrical characteristics of an item and comparing those characteristics with prescribed standards.

c. Service. Operations required periodically to keep an item in proper operating condition, i.e., to clean (includes decontaminate, when required), to preserve, to drain, to paint, or to replenish fuel, lubricants, chemical fluids, or gases.

d. Adjust. To maintain or regulate, within prescribed limits, by bringing into proper or exact position, or by setting the operating characteristics to specified parameters.

e. Align. To adjust specified variable elements of an item to bring about optimum performance.

f. Calibrate. To determine and cause corrections to be made or to be adjusted on instruments or test, measuring, and diagnostic equipments used in precision measurement. Consists of comparisons of two instruments, one of which is a certified standard of known accuracy, to detect and adjust any discrepancy in the accuracy of the instrument being compared.

g. Remove /Install To remove and install the same item when required to perform service or other maintenance functions. Install may be the act of emplacing, seating, or fixing into position a spare, repair part, or module (component or assembly) in a manner to allow the proper functioning of an equipment or system.

**B-2. MAINTENANCE FUNCTIONS - continued.**

h. Replace. To remove an unserviceable item and install a serviceable counterpart in its place. "Replace" is authorized by the MAC and is shown as the 3id position code of the SMR code.

i. Repair. The application of maintenance services, including fault location/troubleshooting, removal / installation, and disassembly/assembly procedures, and maintenance actions to identify troubles, and restore serviceability to an item by correcting specific damage, fault, malfunction, or failure in a part, subassembly, module (component or assembly) end item, or system.

j. Overhaul. That maintenance effort (service/action) prescribed to restore an item to a completely serviceable/operational condition as required by maintenance standards in appropriate technical publications (i.e., DMWR). Overhaul is normally the highest degree of maintenance performed by the Army. Overhaul does not normally return an item to like new condition.

k. Rebuild. Consists of those services/actions necessary for the restoration of unserviceable equipment to a like new condition in accordance with original manufacturing standards. Rebuild is the highest degree of material maintenance applied to Army equipment. The rebuild operation includes the act of returning to zero those age measurements (hours / miles, etc.) considered in classifying Army equipment/components.

**B-3. EXPLANATION OF COLUMNS IN THE MAC- SECTION II.**

a. Column 1. Group Number. Column 1 lists functional group code numbers, the purpose of which is to identify maintenance significant components, assemblies, subassemblies, and modules with the next higher assembly. End item group numbers are "00".

b. Column 2. Component / Assembly. Column 2 contains the names of components, assemblies, subassemblies, and modules for which maintenance is authorized.

c. Column 3. Maintenance Function. Column 3 lists the functions to be performed on the item listed in Column 2. (For a detailed explanation of these functions, see paragraph B-2).

d. Column 4. Maintenance Level. Column 4 specifies, by the listing of a work time figure (expressed as man-hours shown as whole hours or decimals) in the appropriate sub-column(s), the level of maintenance authorized to perform the function listed in Column (3). This figure represents the active time required to perform that maintenance function at the indicated level of maintenance. If the number or the complexity of the tasks within the listed maintenance function vary at different maintenance levels, appropriate work time figures will be shown for each level. The work time figure represents the average time required to restore an item (assembly, subassembly, component, module, end item, or system) to a serviceable condition under typical field operating conditions. This time includes preparation time including any necessary disassembly/assembly time, troubleshooting / fault location time, and quality assurance/quality control time in addition to the time required to perform the specific tasks identified for the maintenance functions authorized in the maintenance allocation chart. The system designations for the various maintenance levels are shown on the following page.

C	Operator or crew
O	Unit Maintenance
F	Direct Support Maintenance
H	General Support Maintenance
D	Depot Maintenance

e. Column 5. Tools and Equipment. Column 5 specifies, by code, those common tool sets (not individual tools) common TMDE , and special tools, special TMDE, and support equipment required to perform the designated function.

f. Column 6. Remarks. This column, when applicable, contains a letter code, in alphabetic order, which is keyed to the remark contained in Section IV.

**B-4. EXPLANATION OF COLUMNS IN TOOL AND TEST EQUIPMENT REQUIREMENTS - SECTION III.**

a. Column 1. Reference Code. The tool and test equipment reference code correlates with a code used in the MAC, Section II, Column 5.

b. Column 2. Maintenance Level. The lowest category of maintenance authorized to use the tool or test equipment.

c. Column 3. Nomenclature. Name or identification of the tool or test equipment.

d. Column 4. National Stock Number. The national stock number of the tool or test equipment.

e. Column 5. Tool Number. The manufacturer's part number.

**B-5. EXPLANATION OF COLUMNS IN REMARKS - SECTION IV.**

a. Column 1. Reference Code. The code recorded in column 6, Section II.

b. Column 2. Remarks. This column lists information pertinent to the maintenance function being performed as indicated in the MAC, Section II.

**Section II. MAINTENANCE ALLOCATION CHART**

(1) GROUP	(2) COMPONENT/ASSEMBLY NUMBER	(3) MAINTENANCE FUNCTION	(4) MAINTENANCE CATEGORY					(5) TOOLS & EQPT	(6) REMARK
			Unit		DS	GS	Depot		
			C	O	F	H	D		
00	500 GALLON FABRIC COLLAPSIBLE DRUM	INSPECT SERVICE REPAIR	0.5	1.03				1,2	AB
01	CAP, ADAPTER, AND NIPPLE	INSPECT REPLACE	0.5	.0				1,2	A
02	SHACKLES, BEARING, SWIVEL, AND CLOSURE PLATES	INSPECT SERVICE REPLACE	0.5	1.0				1,2	A

**Section III. TOOLS AND TEST EQUIPMENT REQUIREMENTS**

(1) REFERENCE CODE	(2) MAINTENANCE CATEGORY	(3) NOMENCLATURE	(4) NATIONAL/NATO STOCK NUMBER	(5) TOOL NUMBER
1	O	TOOL KIT,GENERAL MECHANICS	5180-00-177-7033	SC-5180-90-CL-N26
2	O	SHOP EQUIPMENT AUTOMOTIVE VEHICLE	4910-00-754-0654	SC-4910-95-CL-A74

**Section IV. REMARKS**

REFERENCE CODE	REMARKS
A	REPAIR LIMITED TO REPLACEMENT OF DEFECTIVE COMPONENTS
B	OPERADR LIMIIED TO USE OF EMERGENCY KIT FOR REPAIR OF DRUM.



**APPENDIX C**  
**UNIT MAINTENANCE REPAIR PARTS**  
**AND SPECIAL TOOLS LIST**  
**SECTION I. INTRODUCTION**

**1. SCOPE.** This RPSTL lists and authorizes spares and repair parts; special tools; special test, measurement, and diagnostic equipment (TMDE); and other special support equipment required for performance of unit, direct support, and general support maintenance of the 500 Gallon Collapsible Liquid Fuel Drum, Low Temperature . It authorizes the requisitioning, issue, and disposition of spares, repair parts and special tools as indicated by the source, maintenance and recoverability (SMR) codes.

**2. GENERAL** In addition to this section, Introduction, this Repair Parts and Special Tools List is divided into the following sections:

**a. Section II. Repair Parts List.** A list of spares and repair parts authorized by this RPSTL for use in the performance of maintenance. This list also includes parts which must be removed for replacement of the authorized parts. Parts lists are composed of functional groups in ascending alphanumeric sequence, with the parts in each group listed in ascending figure and item number sequence. Bulk materials are listed in item name sequence. Items listed are shown on the associated Illustration(s) / (figure(s)).

**b. Section III. Special Tools List.** A list of special tools, special TMDE, and other special support equipment authorized by this RPSTL (as indicated by Basic of Issue (BOI) information in DESCRIPTION AND USABLE ON CODE column) for the performance of maintenance.

**c. Section IV. Cross references Indexes.** A list, in National Item Identification Number (NIIN) sequence, of all National stock numbered items appearing in the listing, followed by a list in alphanumeric sequence of all part numbers appearing in the listings. National stock numbers and part numbers are cross-referenced to each illustration figure and item number appearance. The figure and item number index lists figure and item number in alphanumeric sequence and cross-references NSN, CAGEC and part number.

**3. EXPLANATION OF COLUMNS (SECTION II AND III).**

**a. Item No. (Column (1)).** Indicates the number used to identify items called out in the illustration.

**b. SMR Code (Column (2)).** The Source, Maintenance, and Recoverability (SMR) code is a 5-position code containing supply/requisitioning information, maintenance category authorization criteria, and disposition instruction, as shown in the following breakout:

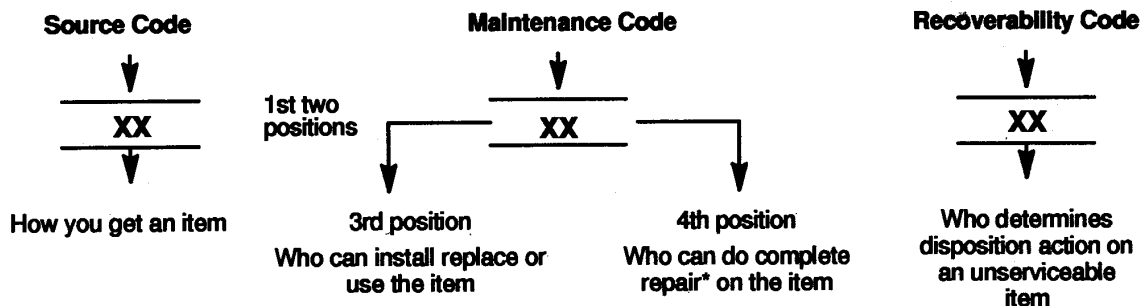

\* Complete Repair: Maintenance capacity, capability, and authority to perform all corrective maintenance tasks of the "Repair" function in a use/user environment in order to restore serviceability to a failed item.

(1) **Source Code.** The source code tells you how to get an item needed for maintenance, repair, or overhaul of an end item/equipment. Explanations of source codes follows:

Source Code	Explanation
PA PB PC** PD PE PF PG	<p>Stocked items; use the applicable NSN to request/requisition items with these source codes. They are authorized to the category indicated by the code entered in the 3rd position of the SMR code.</p> <p>** NOTE: Items coded PC are subject to deterioration.</p>
KD KF KB	<p>Items with these codes are not to be requested/requisitioned individually. They are part of a kit which is authorized to the maintenance category indicated in the 3rd position of the SMR code. The complete kit must be requisitioned and applied.</p>

MO (Made at org. AVUM level) MF (Made at DS/AVUM level) MH (Made at GS level) ML (Made at Specialized Repair Activity (SRA)) MD (Made at Depot)	<p>Items with these codes are not to be requested/requisitioned individually. They must be made from bulk material which is identified by the part number in the DESCRIPTION and USABLE ON CODE (UOC) column and listed in the Bulk Material group of the repair parts list in the RPSTL. If the item is authorized to you by the 3rd position code of the SMR code, but the source code indicates it is made at a higher level, order the item from the higher level of maintenance.</p>
---	---

AO (Assembled by org AVUM Level) AF (Assembled by DS/AVUM Level) AH (Assembled by GS Category) AL (Assembled by SRA) AD (Assembled by Depot)	<p>Items with these codes are not to be requested/requisitioned individually. The parts that make up the assembled item must be requisitioned or fabricated and assembled at the level of maintenance indicated by the source code. If the 3rd position code of the SMR code authorizes you to replace the item, but the source code indicates the items are assembled at a higher level, order the item from the higher level of maintenance.</p>
--	--

XA - Do not requisition an "XA"-coded item. Order its next higher assembly. (Also, refer to the NOTE below.)

- XB - If an 'XB' item is not available from salvage, order it using the CAGEC and part number given.
- XC - Installation drawing, diagram, instruction sheet, field service drawing, that is identified by manufacturer's part number.
- XD - Item is not stocked. Order an 'XD'-coded item through normal supply channels using the CAGEC and part number given, if no NSN is available.

**NOTE**

**Cannibalization or controlled exchange, when authorized, may be used as a source of supply for items with the above source codes, except for those source coded "XA" or those aircraft support items restricted by requirements of AR 750-1.**

**(2) Maintenance Code.** Maintenance codes tell you the level(s) of the maintenance authorized to USE and REPAIR support items. The maintenance codes are entered in the third and fourth positions of the SMR code as follows:

**(a)** The maintenance code entered in the third position tells you the lowest maintenance level authorized to remove, replace, and use an item. The maintenance code entered in the third position will indicate authorization to one of the following levels of maintenance.

**Maintenance**

<b>Code</b>	<b>Application/Explanation</b>
C -	Crew or operator maintenance done within unit/AVUM maintenance.
O -	Unit level AVUM can remove, replace, and use the item.
F -	Direct support/AVIM maintenance can remove, replace, and use the item.
H -	General support level can remove, replace, and use the item.
L -	Specialized repair activity can remove, replace, and use the item.
D -	Depot level can remove, replace, and use the item.

**(b)** The maintenance code entered in the fourth position tells whether or not the item is to be repaired and identifies the lowest maintenance level with the capability to do complete repair (i.e., perform all authorized repair functions).

**NOTE:**

**Some limited repair may be done on the item at a lower level of maintenance, if authorized by the Maintenance Allocation Chart and SMR codes.**

**Maintenance**

<b>Code</b>	<b>Application/Explanation</b>
O -	Unit/AVUM is the lowest level that can do complete repair of the item.
F -	Direct support/AVIM is the lowest level that can do complete repair of the item.
H -	General support is the lowest level that can do complete repair of the item.
L -	Specialized repair activity is the lowest level that can do complete repair of the item.
D -	Depot is the lowest level that can do complete repair of the item.
Z -	Non-repairable. No repair is authorized.
B -	No repair is authorized. No parts or special tools are authorized for the maintenance of a "B" coded item. However, the item may be reconditioned by adjusting, lubricating, etc., at the user level.

(3) **Recoverability Code.** Recoverability codes are assigned to items to indicate the disposition action on unserviceable items. The recoverability code is entered in the fifth position of the SMR Code as follows:

**Recoverability**

Code	Application/Explanation
Z	- Non-repairable item. When unserviceable, condemn and dispose of the item at the level of maintenance shown in 3rd position of SMR Code.
O	- Repairable item. When not economically repairable, condemn and dispose of the item at unit or AVUM level.
F	- Repairable item. When uneconomically repairable, condemn and dispose of the item at the direct support or AVIM level.
H	- Repairable item. When uneconomically repairable, condemn and dispose of the item at the general support level.
D	- Repairable item. When beyond lower level repair capability, return to depot. Condemnation and disposal of item not authorized below depot level.
L	- Repairable item. Condemnation and disposal not authorized below specialized repair activity (SRA).
A	- Item requires special handling or condemnation procedures because of specific reasons (e.g., precious metal content, high dollar value, critical material, or hazardous material). Refer to appropriate manuals/directives for specific instructions.

c. **CAGEC (Column (3)).** The Commercial and Government Entity Code (CAGEC) is a 5-digit numeric code which is used to identify the manufacturer, distributor, or Government agency, etc., that supplies the item.

d. **PART NUMBER (Column (4)).** Indicates the primary number used by the manufacturer, (individual, company, firm, corporation, or Government activity), which controls the design and characteristics of the item by means of its engineering drawings, specification standards, and specification requirements to identify an item or range of items.

**NOTE**

**When you use an NSN to requisition an item, the item you receive may have a different part number from the part ordered.**

e. **DESCRIPTION AND USABLE ON CODE (UOC) (Column (5)).** This column includes the following information:

- (1) The Federal item name and, when required, a minimum description to identify the item.
- (2) Part number of bulk materials are reference in this column in the line entry to be manufactured/fabricated.
- (3) The statement "END OF FIGURE" appears just below the last item description in Column(5) for a given figure in both Section II and Section III.

f. **QTY (Column (6)).** The QTY (quantity per figure )column indicates the quantity of the item used in the breakout shown on the illustration figure, which is prepared for a functional group, sub-functional group, or an assembly. A "V" appearing in this column in lieu of a quantity indicates that the quantity is variable and may vary from application to application.

**4. EXPLANATION OF COLUMNS (SECTION IV).**

**a. NATIONAL STOCK NUMBER (NSN) INDEX.**

(1) **STOCK NUMBER COLUMN.** This column lists the NSN by national item identification number (NIIN) sequence. The NIIN consists of the last nine digits of the NSN, i.e..

NSN  
8110-01-327-1981  
NIIN

When using this column to locate an item, ignore the first four digits of the NSN. Use the complete NSN (13 digits) when requisitioning by stock number..

(2) **FIG. Column.** This column lists the number of the figure where the item is identified located. The figures are in numerical order in Section II and Section III.

(3) **ITEM Column.** The item number identifies the item associated with the figure listed in the adjacent FIG. column. This item is also identified by the NSN listed on the same line.

**b. PART NUMBER INDEX.** Part numbers in this index are listed by part number in ascending alphanumeric sequence (i.e., vertical arrangement of letter and number combination which places the first letter or digit of each group in order A through Z, followed by the numbers 0 through 9 and each following letter or digit in like order).

(1) **CAGEC Column.** The Commercial and Government Entity Code (CAGEC) is a 5-digit numeric code used to identify the manufacturer, distributor, or Government agency/activity that supplies the item.

(2) **PART NUMBER Column.** Indicates the primary number used by the manufacturer (individual, firm, corporation, or Government activity), which controls the design and characteristics of the item by means of its engineering drawings, specifications standards, and inspection requirements to identify an item or range of items.

(3) **STOCK NUMBER Column.** This column lists the NSN for the associated part number and manufacturer identified in the PART NUMBER and CAGEC columns to the left.

(4) **FIG. Column.** This column lists the number of the figure where the item is identified/located in Section II and Section III..

(5) **ITEM Column.** This ITEM number is that number assigned to the item as it appears in the figure referenced in adjacent figure number column.

**c. FIGURE AND ITEM NUMBER INDEX**

(1) **Fig. Column.** This lists the number of the figure where the item is identified/located in Section II and Section III.

(2) **ITEM Column.** This item number is that number assigned to the item as its appears in the figure referenced in the adjacent number column.

(3) **STOCK NUMBER Column.** This column lists the NSN for the item.

(4) **CAGEC Column.** The Commercial and Government Entity Code (CAGEC) is a 5-digit numeric code used to identify the manufacturer, distributor, or Government agency/activity that supplies the item. In Section II and Section III.

(5) **PART NUMBER Column.** Indicates the primary number used by the manufacturer (individual, firm, corporation, or Government activity), which controls the design and characteristics of the item by means of its engineering drawings, specifications, standards, and inspection requirements to identify an item or range of items.

## 5. **SPECIAL INFORMATION.**

a. **USABLE ON CODE.** The usable on code appears in the lower left corner of the Description column heading. Usable on codes are shown as "UOC:.." in the Description Column (justified left) on the last line applicable item description/nomenclature. Uncoded items are applicable to all models.

b. **FABRICATION INSTRUCTIONS.** Bulks materials required to manufacture items are listed in the Bulk Material Functional Group of this RPSTL. Part number for bulk materials are also referenced in the description column of the line entry for the item to be manufactured/fabricated. Detailed fabrication instructions for items source coded are found in Appendix G of this manual.

c. **INDEX NUMBERS.** Items which have the BULK in the figure column will have an index number shown in the item number column. This index number is a cross-reference between the National Stock Number/Part Number Index and the bulk material list in Section II.

## 6. **HOW TO LOCATE REPAIR PARTS.**

### a. **When National Stock Number or Part Number Is NOT Known.**

(1) **First.** Using the table of contents, determine the assembly or subassembly group to which the item belongs. This is necessary since figures are prepared for assembly groups and subassembly groups, and listing are divided into the same groups.

(2) **Second.** Find the figure covering the assembly group or subassembly group to which the item belongs.

(3) **Third.** Identify the item on the figure and use the Figure and Item Number Index to find the NSN.

### b. **When National Stock Number or Part Number is Known.**

(1) **First.** Using the National Stock Number and Part Number Indexes find the pertinent National Stock Number or Part Number. The NSN index is in National Item Identification Number (NIIN) sequence (see 4.a.). The part numbers in the Part Number index are listed in ascending alphanumeric sequence (see paragraph 4.b.). Both indexes cross-reference you to the illustration/ figure and item number of the item you are looking for.

(2) **Second.** Turn to the figure and item number, verify that the item is the one you are looking for, then locate the item number in the repair parts list for the figure.

7. **ABBREVIATIONS.** Abbreviations used in this manual are listed in MIL-STD-12.

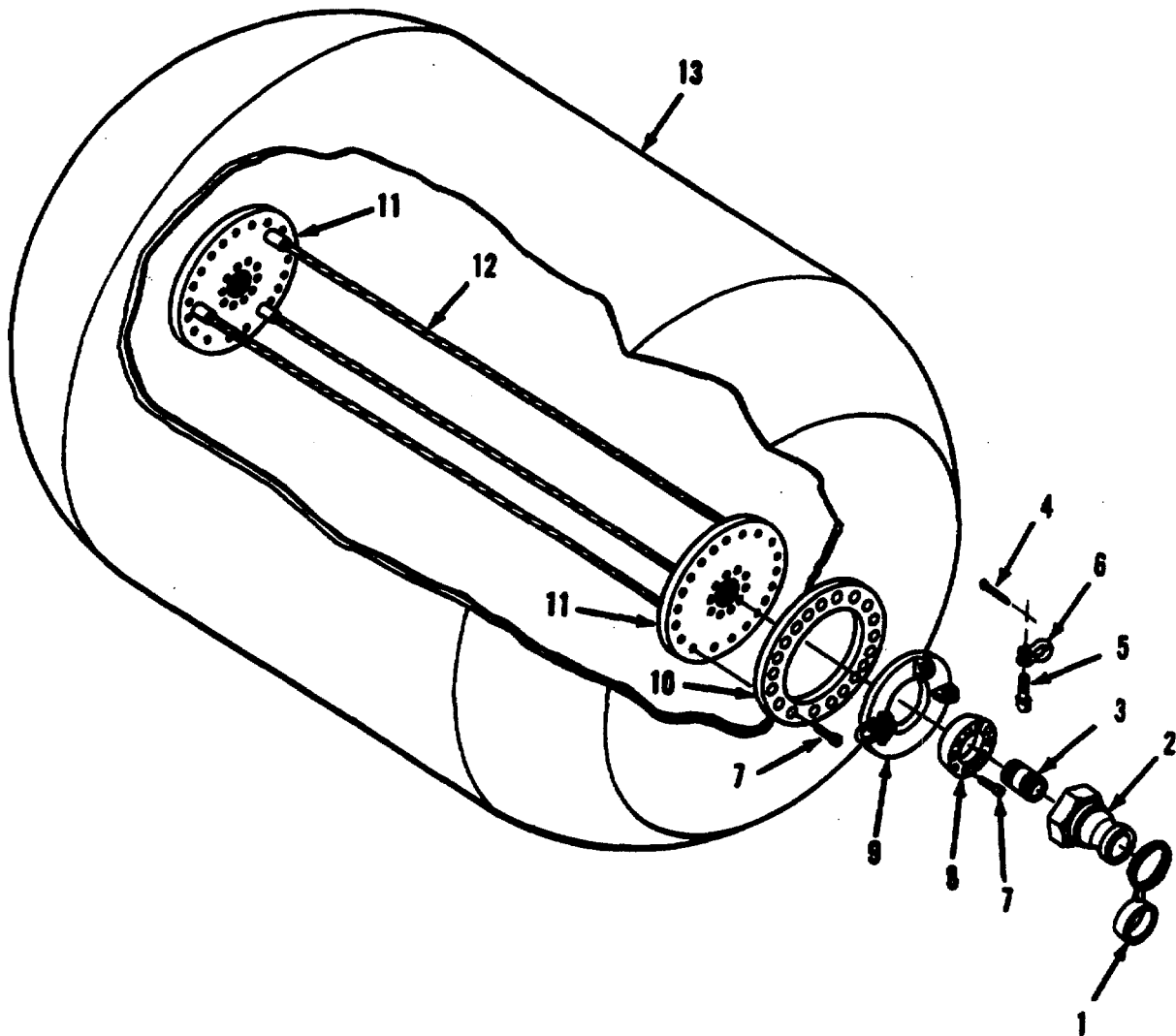

Figure C-1. 500 Gallon Collapsible Liquid Fuel Drum

(C-7 blank)/C-8

## SECTION II

TM 10-8110-203-12&amp;P

(1) ITEM NO	(2) SMR CODE	(3) CAGEC	(4) PART NUMBER	(5) DESCRIPTION AND USABLE ON CODES(UOC)	(6) QTY
<b>GROUP 00 500 GALLON FABRIC COLLAPSIBLE DRUM</b>					
<b>FIG. 1 500 GALLON FABRIC COLLAPSIBLE DRUM</b>					
1	XBOZZ	97403	13228E3192	CAP, PROTECTIVE .....	2
2	PBOZZ	9H113	1611AN-3	COUPLING HALF, QUICK.....	2
3	PBOZZ	97403	13218E0612-104	NIPPLE, PIPE .....	2
4	PBOZZ	96906	MS24665-372	PIN, COTTER .....	4
5	PBOZZ	97403	13216E9193	BOLT, SHOULDER .....	4
6	XBOZZ	96169	75917-54XIPC1	SHACKLE5/8 IN .....	4
7	PBOZZ	96906	MS16997-101	SCREW, CAP, SOCKET H E .....	62
8	XBOZZ	97403	13216E9168	PLATE, BEARING .....	2
9	XBOZZ	97403	13216E9163	PLATE, SWIVEL .....	2
10	XAFZZ	97403	13216E9183	SPACER, PLATE .....	2
11	XAFZZ	97403	13228E3194-1	PLATE, CLO SURE .....	1
12	XAFZZ	97403	13216E9167-2	WIRE ROPE ASSEMBLY, .....	3
13	XAFZZ	66618	13228E1848	BODY, DRUM LOW TEMP .....	1

END OF FIGURE

C-9/(C-10 blank)



CROSS-REFERENCE INDEXES  
NATIONAL STOCK NUMBER INDEX

STOCK NUMBER	FIG.	ITEM	STOCK NUMBER	FIG.	ITEM
5315-00-059-0491	1	4			
5305-00-978-9396	1	7			
5306-01-118-1915	1	5			
4730-01-294-8141	1	2			
4730-01-415-0997	1	3			

## CROSS-REFERENCE INDEXES

PART NUMBER INDEX				
CAGEC	PART NUMBER	STOCK NUMBER	FIG.	ITEM
96906	MS16997-101	5305-00-978-9396	1	7
96906	MS24665-372	5315-00-059-0491	1	4
97403	13216E9163		1	99
97403	13216E9167-2		1	12
97403	13216E9168		1	8
97403	13216E9183		1	10
97403	13216E9193	5306-01-118-1915	1	5
97403	13218E0612-104	4730-01-415-0997	1	3
66618	13228E1848		1	13
97403	13228E3192		1	1
97403	13228E3194-1		1	11
9H113	1611AN-3	4730-01-294-8141	1	2
96169	75917-54X1PC1		1	6

## CROSS-REFERENCE INDEXES

## FIGURE AND ITEM NUMBER INDEX

FIG.	ITEM	STOCK NUMBER	CAGEC	PART NUMBER
1	1		97403	13228E3192
1	2	4730-01-294-8141	9H113	1611AN-3
1	3	4730-01-415-0997	97403	13218E0612-104
1	4	5315-00-059-0491	96906	MS24665-372
1	5	5306-01-118-1915	97403	13216E9193
1	6		96169	75917-54X1PC1
1	7	5305-00-978-9396	96906	MS16997-101
1	8		97403	13216E9168.
1	9		97403	13216E9163
1	10		97403	13216E9183
1	11		97403	13228E3194-1
1	12		97403	13216E9167-2
1	13		66618	13228E1848

C-13/(C-14 blank)

## APPENDIX D

COMPONENTS OF END ITEM AND BASIC ISSUE ITEMS LIST

---

## Section I. INTRODUCTION

**D-1. SCOPE.**

This appendix lists components of end item and basic issue items for the 500 gallon drum to help you inventory items required for safe and efficient operation.

**D2. GENERAL.**

The Components of End Item and Basic Issue Items List are divided into the following sections:

**a. Section II. Components of End Item.** This listing is for informational purposes only, and is not authority to requisition replacements. These items are part of the end item, but are removed and separately packaged for transportation or shipment. As part of the end item, these items must be with the end item whenever it is issued or transferred between property accounts. Illustrations are furnished to assist you in identifying the items.

**b. Section III. Basic Issue Items.** These are the minimum essential items required to place the 500 gallon drum in operation. Although shipped separately packaged, BH must be with the distribution system during operation and whenever it is transferred between property accounts. The illustrations will assist you with hard-to-identify items. This manual is your authority to request/requisition replacement BII, based on TOE/MTOE authorization of the end item.

**D-3. EXPLANATION OF COLUMNS.**

The following provides an explanation of columns found in the tabular listing

**a. Column (1) - Illustration Number (Illus Number).** This column indicates the number of the illustration in which the item is shown

**b. Column (2) - National Stock Number.** Indicates the national stock number assigned to the item and will be used for requisitioning purposes.

**c. Column (3) - Description.** Indicates the Federal item and name and, if required, a minimum description to identify and locate the item. The last line for each item indicates the CAGE (in parentheses) followed by the part number.

**d. Column (4) - Unit of Measure U(/M).** Indicates the measure used in performing the actual operational/maintenance function. This measure is expressed by a two character alphabetical abbreviation (e.g., ea, in, pr).

**e. Column (5) - Quantity required (Qty rqd).** Indicates the quantity of the item authorized to be used with/on the equipment.

Section II. COMPONENTS OF END ITEM

(1) ILLUS NUMBER	(2) NATIONAL STOCK NUMBER	(3) DESCRIPTION CAGE and Part Number	Usable on Code	(5) QTY. RQD
1		CAP, PROTECTIVE (97403) 13228E3192	Ea	2
2		ADAPIER, QUICK DISCONNECT (97403) 13228E1851	Ea	2
3		NIPPLE, THREADED (97403) 13218E0612-104	Ea	2
4		BODY, DRUMLOW TEMPERATURE (97403) 1322SE1848	EA	1

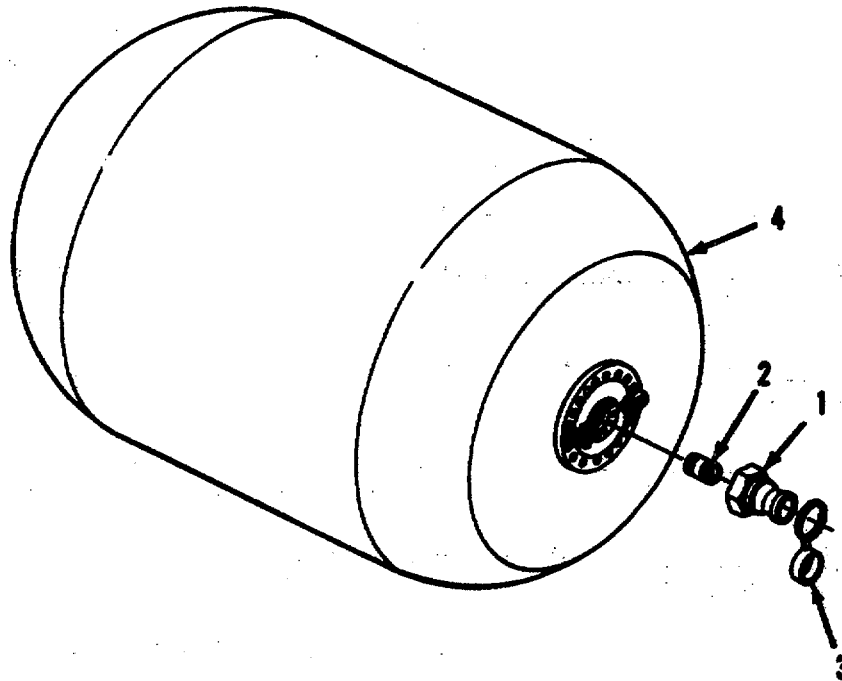

Figure D-1. Components of End Item

Section III. BASIC ISSUE ITEMS

(1) ILLUS NUMBER	(2) NATIONAL STOCK NUMBER	(3) DESCRIPTION CAGE and Part Number	(4) U/M	(5) QTY. RQD
1		TECHNICAL MANUAL, OPERATOR'S AND UNIT MAINTENANCE, INCLUDING REPAIR PARTS AND SPECIAL TOOLS LIST. TM 10-8110-203-12&P	EA	1

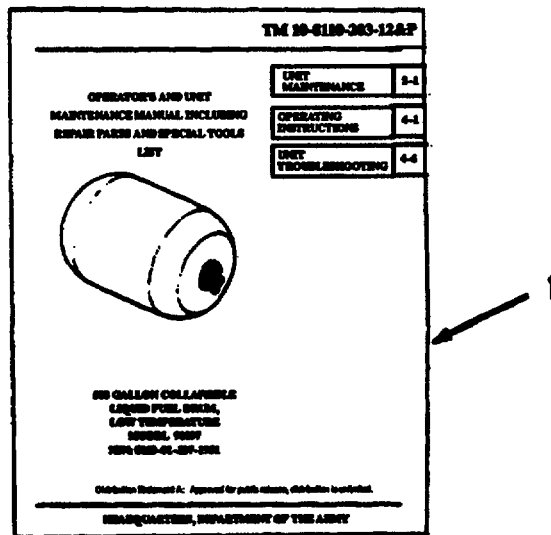

Figure D-2. Basic Issue Item

D-3/(D-4 blank)

APPENDIX E

ADDITIONAL AUTHORIZATION LIST

Section I. Introduction.

**E-1. SCOPE.**

This append lists additional items you are authorized for the support of the 500 gallon drum.

**E-2. GENERAL**

This list identifies items that do not have to accompany the 500 gallon drum and that do not have be turned in with it These items all authorized to you by CTA, MTOE, TDA, or JTA.

**E-3. EXPLANATION OF LISTING.**

National stock number, descriptions and quantities are provided to help you identify and request the additional items you require to support this equipment. The items are listed in alphabetical sequence by item name. If the item you require differs between serial numbers of the same model, effective serial numbers are shown in the last line of the description. If item required differs for different models of this equipment, the model is shown under the "Usable on" heading in the description column.

Section II. Additional Authorization Items List

(1) NATIONAL STOCK NUMBER	(2) DESCRIPTION CAGEC AND PART NMBER USABLE ON CODE	(3) U/I	(4) QTY AUTH
8110-01-85-62 46 62	Emergency Repair Kit Type II	Ea	1
8110-01-856-6245	Tiedown Kit	Ea	1
8110-01-856-6243	Yoke, Towing and Lifting	Ea	1

E-1/(E-2 blank)

## APPENDIX F

EXPENDABLE/DURABLE SUPPLIES AND MATERIALS LIST

---

## Section I. INTRODUCTION

## F-1. SCOPE.

This appendix lists expendable/durable supplies and materials you will need to operate and maintain the 500 Gallon Drum. This listing is for informational purpose only and is not authority to requisition the listed items. These items are authorized to you by CTA 50-970, Expendable/Durable Items (Except Medical, Class V, Repair Parts, and Heraldic Items), or CTA 8-100, Army Medical Department Expendable/Durable Items.

## F-2. EXPLANATION OF COLUMNS.

a. **Column 1 - Item Number.** This number is assigned to the entry in the listing and is referenced in maintenance procedures to identify the material.

b. **Column 2 - Category.** This column identified the lowest category of maintenance that requires the listed item:

- C - Operator/Crew
- O - Unit Maintenance
- F - Direct Support Maintenance
- H - General Support Maintenance

c. **Column 3 - National Stock Number.** This is the national stock number assigned to the item; use it to request or requisition the items.

d. **Column 4 - Description.** Indicates the federal item name and, if required, a description to identify the item. The last line for each item indicates the part number followed by the Commercial And Government Entity (CAGE) Code for Manufacturer in parentheses, if applicable.

e. **Column 5 - Unit of Measure (U/M).** Indicates the measure used in performing the actual maintenance function. This measure is expressed by a two character alphabetical abbreviation (e.g. ea, in, pr). If the unit of measure differs from the rest of the issue, requisition the lowest unit of issue that will satisfy your requirements.



## Section II. EXPENDABLE/DURABLE SUPPLIES AND MATERIALS LIST

Item Number	Category	Stock Number	Description	U/M
1	C		Sealant, Thread with Teflon P/N 13228E1791	Tube
2	C	7920-00-148-9666	Rags, Wiping, DDD-R-30G	Bale
3	O	6850-00-664-5685	Dry cleaning solvent, A-A-711, Type I	Qt.

APPENDIX G

ILLUSTRATED LIST OF MANUFACTURED ITEMS

---

NOT APPLICABLE

G-1/(G-2 blank)

APPENDIX H  
TORQUE LIMITS

---

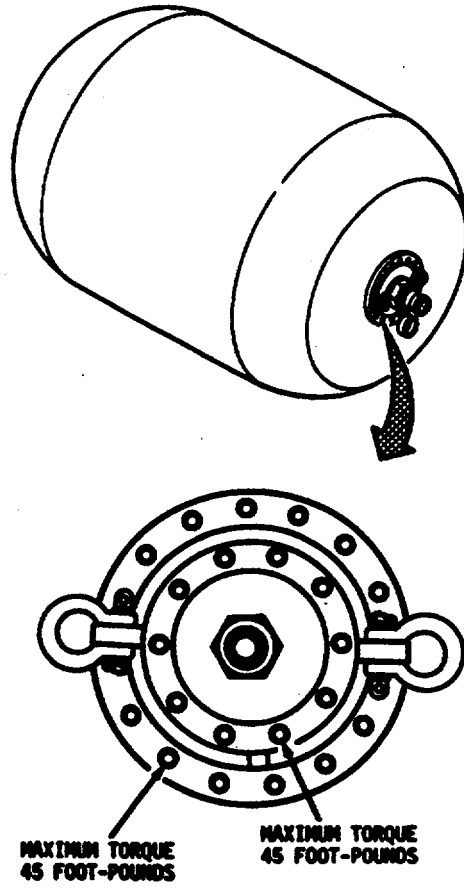

Figure H-1. Torque Limits

H-1/(H-2 blank)

**GLOSSARY**

---

**Section I. ABBREVIATIONS**

°F	Degrees Fahrenheit
CPC	Corrosion Prevention and Control
MPH	Miles per hour
NBC	Nuclear, Biological and Chemical
NSN	National Stock Number
PN	Part Number
PSIG	Pound-force per Square Inch. Gage
RPSTL	Repair Parts and Special Tools list

---

**Section II. DEFINITIONS OF UNUSUAL TERMS**

Ambient                      Surrounding on all sides (environmental).

**Glossary 1/(Glossary 2 blank)**

INDEX

SUBJECT, PARAGRAPH

SUBJECT, PARAGRAPH

**-A-**

Abbreviations, List of, 1-7  
 Adapter, Quick-Disconnect, 1-9g  
 Adapter, Quick-Disconnect,  
 Replacement, 4-10  
 Additional Authorization List, E-1  
 Administrative, 4-15  
 Arctic Cold Conditions, Operating In, 2-8a  
 Assembly and Preparation for Use, 2-5

**-B-**

Basic issue Items, D-3  
 Bearing Plate, 1-9e  
 Body, Drum, 1-9a

**-C-**

Characteristics, Capabilities and  
 Features, 1-8  
 Checks and Services, Preventive  
 Maintenance, 2-1  
 Closure Plate, 1-9b  
 Closure Ring, 1-9c  
 Commercial and Government Entity Code (CAGE), C -4  
 Common Tools and Equipment, 4-1  
 Components of End item and Basic  
 Issue items List, D-1  
 Controls and Indicators, 2-1  
 Corrosion Prevention and Control, 1-4  
 Cross Reference Index, C-11

**-D-**

Data, Equipment, 1-10  
 Decals and Instruction Plates, 2-7  
 Decontamination Procedures NBC, 2-10  
 Description of Major Components, 1-9  
 Destruction of Army Materiel To  
 Prevent Enemy Use, 1-3  
 Dispensing Fuel, 2-6  
 Drum Body, 1-9a

**-E-**

Emergency Procedures, 2-9  
 Emergency Repair, 3-3  
 Equipment Characteristics, Capabilities  
 and Features, 1-8

Equipment Data, 1-10  
 Equipment Improvement Recommendations,  
 Reporting, 1-5  
 Expendable/durable Supplies and  
 Materials List, F-1  
 Extreme Heat, Operating In, 2-8b

**-F-**

Fabrication Instructions, C-6  
 Figure and item index, C-13  
 Filing the Drum, 2-6  
 Forms and Records, Maintenance, 1-2  
 Fuel Dispensing, 2-6  
 General Information, 1-1  
 Glossary, Glossary 1

**-H-**

To Use Manual, iii

**-I-**

Illustrated List of Manufactured Items, G-1  
 Inlet/Outlet Connections, 1-10e  
 Instruction Plates, and Decals, 2-7  
 Introduction, 1-1

**-J-**

**-K-**

**-L-**

Leakage Definitions, 2-3  
 List of Abbreviation, Glossary- 1  
 Locate Repair Parts, C-6  
 Location and Description of Major  
 Components, 1-9  
 Lubrication Instructions, 3-1

**-M-**

Maintenance Allocation Chart, B-1  
 Maintenance Code, C-3  
 Maintenance Forms and Procedures, 1-2  
 Maintenance Functions, B-1  
 Maintenance Procedures, Operator, 3-3  
 Maintenance, Unit, 4-1

INDEX (continued)

**SUBJECT, PARAGRAPH**

**SUBJECT, PARAGRAPH**

Major Components, Location and Description, 1-9  
 Movement, Preparation for, 4-14

**-N-**

National Stock Number, C-5  
 National Stock Number index, C-11  
 Nipple, Pipe, 1-9f  
 Nomenclature Cross Reference List, 1-6  
 Nuclear, Biological and Chemical (NBC) Decontamination Procedures 2-10

**-O-**

Operating Procedures, 2-6  
 Operating Temperature Range, 1-10d  
 Operation Under Unusual Conditions, 2-8  
 Operation Under Usual Conditions, 2-6

Operation Principles of, 1-11  
 Operator Preventive Maintenance Checks and Services, 2-1  
 Operator Troubleshooting, 3-1

**-P-**

Part Number Index C-12  
 Parts, Repair, 4-3  
 Personnel Safety, 4-8  
 Pipe Nipple, 1-9f  
 Plate, Closure 1-9b  
 Plate, Swivel, 1-9d  
 PMCS Operator, 2-1  
 PMCS Unit, 4-2  
 Preparation for Movement, 4-14  
 Prevention and Control, Corrosion, 1-4  
 Principles of Operation, 1-11  
 Proper Equipment, 4-9

**-Q-**

Quick-Disconnect Adapter, 1-9g

**-R-**

Recoverability Code, C 4 References, A-1  
 Repair Parts, 4-3  
 Repair Parts and Special Tools List, C-1

Repair, Towing and Lifting Yoke, 4-12  
 Replace Shackles, Bearing, Swivel, and Closure Plates, 4-11  
 Replace Quick-Disconnect Adapter, 4-10  
 Reporting Equipment Improvement Recommendations, 1-5  
 Ring, Closure 1-9c

**-S-**

Safety, Personnel, 4-8  
 Sandy or Dusty Conditions, Operating In, 2-8c  
 Scope, 1-1  
 Security Procedures, 4-13  
 Service Upon Receipt, 4-4  
 Special Tools, TMDE, and Support Equipment, 4-2  
 Source, Maintenance and Recoverability Code, C-1  
 Source Code, C-2  
 Strong Winds, Operating in, 2-8c  
 Swivel Plate, 1-9d  
 System Technical Principles of Operation, 1-11

**-T-**

Temperature Range, Operating, 1-10d  
 Tools and Test Equipment Requirements, B-4  
 Towing the Drum, 4-14b  
 Transporting by Aircraft, 4-14c  
 Troubleshooting, 3-1, 4-5

**-U-**

Unit Maintenance Procedures, 4-7  
 Unit Troubleshooting Procedures, 4-6  
 Unusual Conditions, Operation Under, 2-8  
 Usual Conditions, Operation Under, 2-6

**-V-**

**-W-**

Warnings, a  
 Warnings and Cautions, 2-2  
 Weight, 1-10c

**-X-**

**-Y-**

**-Z-**

By Order of the Secretary of the Army:

DENNIS J. REIMER  
*General, United States Army*  
*Chief of Staff*

**Official:**

JOEL B. HUDSON  
*Administrative Assistant to the*  
*Secretary of the Army*  
01934

**DISTRIBUTION:**

To be distributed in accordance with DA Form 12-25-E, block no. 6344, requirements for TM 10-8110-203-12&P

**These are the instructions for sending an electronic 2028**

The following format must be used if submitting an electronic 2028. The subject line must be exactly the same and all fields must be included; however only the following fields are mandatory: 1, 3, 4, 5, 6, 7, 8, 9,10,13,15,16,17, and 27.

From: "Whomever" <whomever@avma27.army.mil>

To: mpmt%avma28@st-louis-emh7.army. mil

Subject: DA Form 2028

1. **From:** Joe Smith
2. **Unit:** home
3. **Address:** 4300 Park
4. **City:** Hometown
5. **St:** MO
6. **Zip:** 77777
7. **Date Sent::** 19-OCT-93
8. **Pub no:** 55-2840-229-23
9. **Pub Title:** TM
10. **Publication Date:** 04-JUL-85
11. **Change Number:** 7
12. **Submitter Rank:** MSG
13. **Submitter FName:** Joe
14. **Submitter MName:** T
15. **Submitter LName:** Smith
16. **Submitter Phone:** 123-123-1234
17. **Problem:** 1
18. **Page:** 2
19. **Paragraph:** 3
20. **Lie:** 4
21. **NSN:** 5
22. **Reference:** 6
23. **Figure:** 7
24. **Table:** B
25. **Item:** 9
26. **Total:** 123
27. **Text:**

This is the text for the problem below line 27.



RECOMMENDED CHANGES TO EQUIPMENT TECHNICAL PUBLICATIONS

 <div style="border: 1px solid black; border-radius: 15px; padding: 5px; display: inline-block; margin-left: 20px;"> <p style="margin: 0;"><i>THEN...JOT DOWN THE DOPE ABOUT IT ON THIS FORM. CAREFULLY TEAR IT OUT, FOLD IT AND DROP IT IN THE MAIL.</i></p> </div>		SOMETHING WRONG WITH PUBLICATION	
		FROM: (PRINT YOUR UNIT'S COMPLETE ADDRESS)	
PUBLICATION NUMBER		DATE SENT	
PUBLICATION DATE		PUBLICATION TITLE	
BE EXACT PIN-POINT WHERE IT IS			
PAGE NO.	PARA- GRAPH	FIGURE NO.	TABLE NO.
<div style="text-align: center; font-weight: bold; margin-bottom: 20px;">IN THIS SPACE, TELL WHAT IS WRONG AND WHAT SHOULD BE DONE ABOUT IT.</div> <div style="border: 1px dashed black; width: 20%; margin: 0 auto; height: 20px;"></div>			
PRINTED NAME, GRADE OR TITLE AND TELEPHONE NUMBER			SIGN HERE

**DA** FORM 1 JUL 79 **2028-2**

PREVIOUS EDITIONS ARE OBSOLETE.

P.S.--IF YOUR OUTFIT WANTS TO KNOW ABOUT YOUR RECOMMENDATION MAKE A CARBON COPY OF THIS AND GIVE IT TO YOUR HEADQUARTERS.

## The Metric System and Equivalents

### *Linear Measure*

1 centimeter = 10 millimeters = .39 inch  
 1 decimeter = 10 centimeters = 3.94 inches  
 1 meter = 10 decimeters = 39.37 inches  
 1 dekameter = 10 meters = 32.8 feet  
 1 hectometer = 10 dekameters = 328.08 feet  
 1 kilometer = 10 hectometers = 3,280.8 feet

### *Weights*

1 centigram = 10 milligrams = .15 grain  
 1 decigram = 10 centigrams = 1.54 grains  
 1 gram = 10 decigram = .035 ounce  
 1 decagram = 10 grams = .35 ounce  
 acres  
 1 hectogram = 10 decagrams = 3.52 ounces  
 1 kilogram = 10 hectograms = 2.2 pounds  
 1 quintal = 100 kilograms = 220.46 pounds  
 1 metric ton = 10 quintals = 1.1 short tons

### *Liquid Measure*

1 centiliter = 10 milliliters = .34 fl. ounce  
 1 deciliter = 10 centiliters = 3.38 fl. ounces  
 1 liter = 10 deciliters = 33.81 fl. ounces  
 1 dekaliter = 10 liters = 2.64 gallons  
 1 hectoliter = 10 dekaliters = 26.42 gallons  
 1 kiloliter = 10 hectoliters = 264.18 gallons

### *Square Measure*

1 sq. centimeter = 100 sq. millimeters = .155 sq. inch  
 1 sq. decimeter = 100 sq. centimeters = 15.5 sq. inches  
 1 sq. meter (centare) = 100 sq. decimeters = 10.76 sq. feet  
 1 sq. dekameter (are) = 100 sq. meters = 1,076.4 sq. feet  
 1 sq. hectometer (hectare) = 100 sq. dekameters = 2.47  
 1 sq. kilometer = 100 sq. hectometers = .386 sq. mile

### *Cubic Measure*

1 cu. centimeter = 1000 cu. millimeters = .06 cu. inch  
 1 cu. decimeter = 1000 cu. centimeters = 61.02 cu. inches  
 1 cu. meter = 1000 cu. decimeters = 35.31 cu. feet

### Approximate Conversion Factors

<i>To change</i>	<i>To</i>	<i>Multiply by</i>	<i>To change</i>	<i>To</i>	<i>Multiply by</i>
inches	centimeters	2.540	ounce-inches	Newton-meters	.007062
feet	meters	.305	centimeters	inches	.394
yards	meters	.914	meters	feet	3.280
miles	kilometers	1.609	meters	yards	1.094
square inches	square centimeters	6.451	kilometers	miles	.621
square feet	square meters	.093	square centimeters	square inches	.155
square yards	square meters	.836	square meters	square feet	10.764
square miles	square kilometers	2.590	square meters	square yards	1.196
acres	square hectometers	.405	square kilometers	square miles	.386
cubic feet	cubic meters	.028	square hectometers	acres	2.471
cubic yards	cubic meters	.765	cubic meters	cubic feet	35.315
fluid ounces	milliliters	29,573	cubic meters	cubic yards	1.308
pints	liters	.473	milliliters	fluid ounces	.034
quarts	liters	.946	liters	pints	2.113
gallons	liters	3.785	liters	quarts	1.057
ounces	grams	28.349	liters	gallons	.264
pounds	kilograms	.454	grams	ounces	.035
short tons	metric tons	.907	kilograms	pounds	2.205
pound-feet	Newton-meters	1.356	metric tons	short tons	1.102
pound-inches	Newton-meters	.11296			

### Temperature (Exact)

°F	Fahrenheit temperature	5/9 (after subtracting 32)	Celsius temperature	°C
----	------------------------	----------------------------	---------------------	----

**PIN: 074648-000**